

DEPARTMENT OF THE ARMY TECHNICAL MANUAL

OPERATOR, ORGANIZATIONAL,
AND FIELD MAINTENANCE MANUAL

NIGHT FIRING TARGET

MECHANISM XM31

This copy is a reprint which includes current pages from Change 1.

HEADQUARTERS, DEPARTMENT OF THE ARMY

MARCH 1962

TECHNICAL MANUAL

Operator, Organizational, and Field Maintenance Manual

TARGET MECHANISM, NIGHT FIRING, SMALL ARMS: XM40

TM 9-6920-205-14

Changes No. 1



HEADQUARTERS,
DEPARTMENT OF THE ARMY
WASHINGTON, D.C., 26 August 1963

TM 9-692020-2014, 8 March 1962, is changed as follows:

Change the title to read as shown above.

Change the reference "night firing target mechanism XM31" to "small arms night firing target mechanism XM40" wherever it appears through- out the technical manual.

Page 2.

1. Scope

* * * * *

f. (Superseded) The direct reporting of errors, omissions, and recommendations for improving this equipment manual by the individual user, is authorized and encouraged. DA Form 2028 will be used for reporting these improvements. This form may be completed using pencil, pen, or typewriter. DA Forms 2028 will be completed in triplicate and forwarded by the individual using the manual. The original and one copy will be forwarded direct to: Commanding Gen-

eral, Headquarters, U.S. Army Weapons Command, Rock Island Arsenal, ATTN: AMSWESMIM, Rock Island, Ill., 61202. One information copy will be provided to the individual's immediate supervisor (e.g., officer, noncommissioned officer, supervisor, etc.).

Page 8.

16. Preparation for Operation

a. At each target * * * assemblies, as follows:

* * * * *

(2) Connect a field * * * each utility box.

Note.

The distance between the target and the location of the flasher chassis and counter chassis assemblies will determine the length of the field wire necessary for each target.

* * * * *

Page 47.

3. Suggestions and Recommendations

Rescinded

By Order of the Secretary of the Army:

EARLE G. WHEELER,
General, United States Army,
Official: Chief of Staff.

Official:

J. C. LAMBERT,
Major General, United States Army,
The Adjutant General.

Distribution:

Active Army:

DCSLOG (1)	ARADCOM Rgn (2)	Ord Sec, GENDEP (2)
CNGB. (1)	OS Maj Comd(2) except	Ord Dep (OS) (3)
TSG (1)	USAREUR (3)	USAOSA (2)
CofEngrs (1)	USARJ (3)	Ord PG (2)
CofT (1)	Base Com (2)	Ord Arsenals (2) except
CSigO (1)	LOGCOMID (3)	Raritan (11)
CofSptS (1)	Armies (3) except	Rock Island (5)
USACDC (1)	Sixth USA (1)	Watervliet (3)
USAOCDA	(2) Corps (2)	Proc Dist (2)
USATCDA	(2) Svc Colleges (2)	USA Corps (2)
USCONARC (3)	Br Svc Sch (2)	Tng Aids Cen (5)
USAMC (2)	Anniston A Dep (3)	Units organized under following
USASMCOMN (5)	Red River A Dep (3)	TOE's (2 copies):
USAMUCOM (2)	Rock Island A Dep (3)	7 9-127
USAWECOM (64)	Tooele A Dep (3)	9-7 17
USATECOM (2)	GENDEP (OS) (3)	9-9 57
ARADCOM (2)		

NG: None.

USAR: None.

For explanation of abbreviations used, see AR 320-50.

TAGO 437A
U.S. GOVERNMENT PRINTING OFFICE: 1963

Technical Manual }
 No. 9-6920-205-14

HEADQUARTERS,
 DEPARTMENT OF THE ARMY
 WASHINGTON 25, D. C., 8 March 1962

NIGHT FIRING TARGET MECHANISM XM31

		Paragraph	Page
CHAPTER	1. INTRODUCTION		
Section	I. General	1-3	2
	II. Description and data.....	4-6	3-5
CHAPTER	2. OPERATING INSTRUCTIONS		
Section	I. Service upon receipt of materiel.....	7-8	6
	II. Controls and instruments.....	9-15	6-8
	III. Operation under usual conditions.....	16-18	8-10
	IV. Operation under unusual conditions.....	19-21	12
CHAPTER	3. ORGANIZATIONAL MAINTENANCE INSTRUCTIONS		
Section	I. Repair parts, tools, and equipment	22-25	13
	II. Preventive-maintenance services.....	26-30	13,14
	III. Replacement of organizational repair parts.....	31-33	15,16
CHAPTER	4. FIELD MAINTENANCE INSTRUCTIONS		
Section	I. Parts, special tools, and equipment for field maintenance.....	34-38	18
	II. Troubleshooting.....	39	18
	III. Repair of cabinet assembly, counter chassis assembly, and flasher chassis assembly	40-43	19-29
	IV. Repair of terminal box assembly, target holder assembly, hit switch assemblies, and utility box assemblies	44-48	35-38
CHAPTER	5. SHIPMENT AND STORAGE	49-51	41,42
APPENDIX	I. REFERENCES.....		43
	II. MAINTENANCE ALLOCATION CHART		45
	III. BASIC ISSUE ITEMS LIST		47
INDEX		49

CHAPTER 1 INTRODUCTION

Section I. GENERAL

1. Scope

a. This technical manual contains instructions for operation and organizational maintenance of the night firing target mechanism XM31 for the using organization, and instructions for field maintenance for Ordnance maintenance personnel.

b. Appendix I contains a list of current references, including supply manuals, forms, technical manuals, and other available publications applicable to target mechanism XM31.

c. Appendix II contains the maintenance allocation chart which lists the maintenance responsibilities allocated to each echelon of maintenance.

d. Appendix III contains the basic issue items which are required by the operator for operating and maintaining the target mechanism XM31.

e. TM 96920-205-24P contains a list of repair parts and special tools for the target mechanism XM31, with allocations for second through fourth echelon maintenance organizations.

f. This first edition is being published in advance of complete technical review. Any errors or omissions will be forwarded on DA Form 2028 direct to the Commanding Officer, Raritan Arsenal, Metuchen, New Jersey, ATTN: ORDJR-OCPRA.

2. Maintenance Allocation

a. *Operator Maintenance Allocation.* The prescribed maintenance to be performed by the operator will apply as reflected in the operator maintenance (first echelon) column of the maintenance allocation chart (app II). In all cases where the nature of the repair, modification, or adjustment is beyond the scope or facilities of the operator, trained organizational maintenance personnel with suitable tools and equipment may be provided or other instructions issued.

b. *Organizational Maintenance Allocation.* The prescribed maintenance to be performed by

maintenance personnel of the using organization will apply as reflected in the organizational maintenance (second echelon) column of the maintenance allocation chart (app II). In all cases where the nature of the repair, modification, or adjustment is beyond the scope or facilities of the using organization, the supporting Ordnance maintenance unit should be informed so that trained personnel with suitable tools and equipment may be provided or other instructions issued.

c. *Field Maintenance Allocation.* The prescribed maintenance to be performed by field maintenance personnel will apply as reflected in the field maintenance columns (3d and 4th) of the maintenance allocation chart (app II).

3. Forms, Records, and Reports

a. *General Responsibility* for the proper execution of forms, records, and reports rests upon the officers of all units maintaining this equipment. However, the value of accurate records must be fully appreciated by all persons responsible for compilation, maintenance, and use. Records, reports, and authorized forms are normally utilized to indicate the type, quantity, and condition of materiel to be inspected, to be repaired, or to be used in repair. Properly executed forms convey authorization and serve as records for repair or replacement of materiel in the hands of troops and for delivery of materiel requiring further repair to Ordnance shops, arsenals, depots, etc. The forms, records, and reports determine the work required, the progress of the work within the shops, and the status of the materiel upon completion of its repair.

b. *Authorized Forms.* The forms generally applicable to units operating or maintaining this materiel are listed in appendix I. For instructions on use of these forms, refer to FM 9-3. For a listing of all forms, refer to DA Pam 310-2.

c. *Field Report of Accidents.* The reports necessary to comply with the requirements of

the Army safety program are prescribed in detail in AR 385-40. These reports are required whenever accidents involving injury to personnel or damage to materiel occur.

d. *Report of Unsatisfactory Equipment or*

Materials. Any deficiencies detected in the equipment herein, which occur under the circumstances indicated in AR 700-38 should be immediately reported in accordance with the applicable instructions in cited regulation.

Section II. DESCRIPTION AND DATA

4. Description (fig. 1)

a. *General.* The night firing target mechanism XM31 is a portable, electro-mechanical training device to be used for training in night firing of small arms. The target mechanism XM31 simulates the flash of a gun and presents a barely discernible silhouette to the soldier(s) firing at it. The target mechanism XM31 permits its operator to control 15 target locations and will

accommodate either kneeling silhouette target "E" or prone silhouette target "F." A 15-volt ac power source is required for operation of the target mechanism XM31. The target mechanism XM31 can be carried by two men and is designed for operation in all temperature and weather conditions under which rifle and machine gun training is conducted.

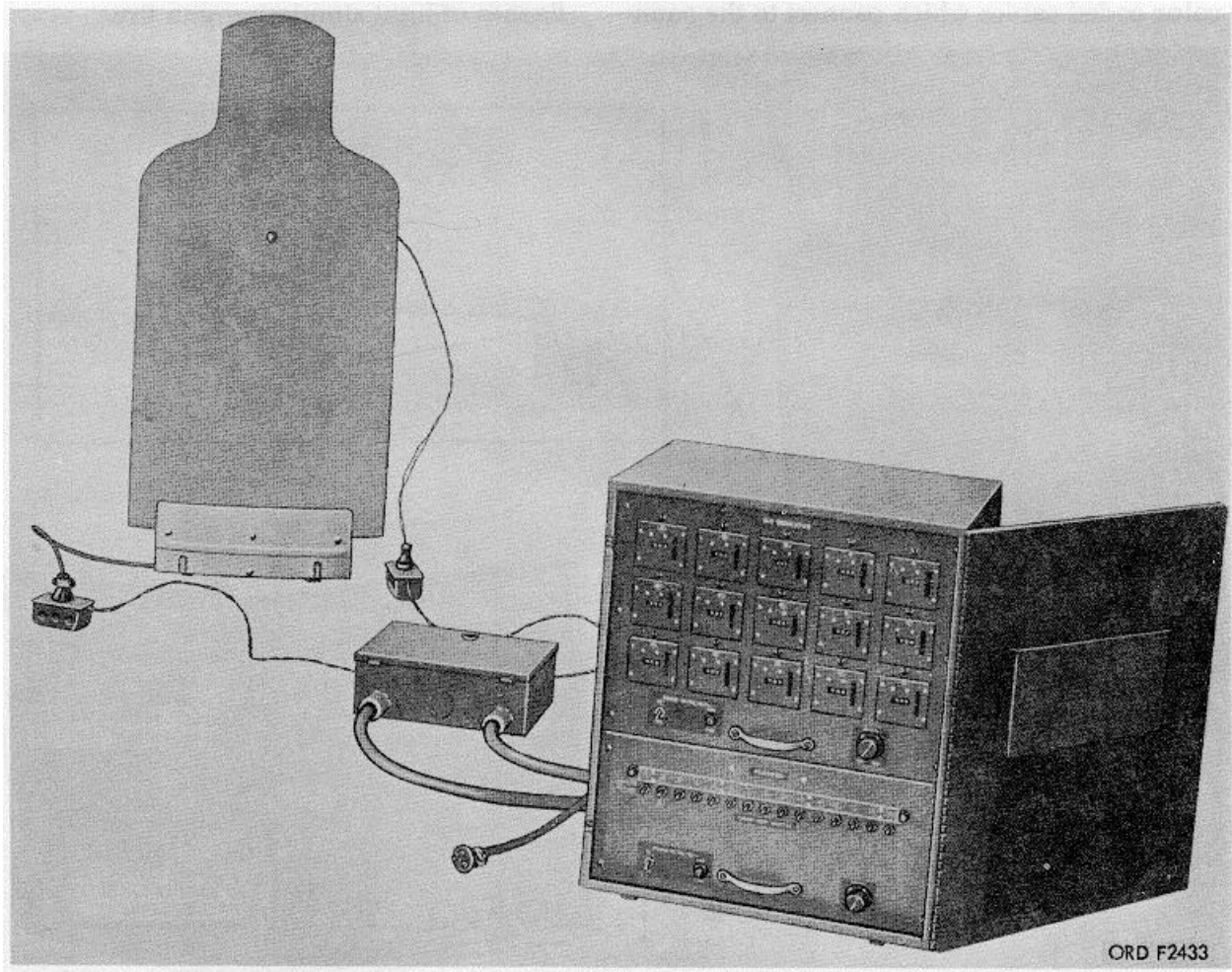

Figure 1. Night firing target mechanism XM31 - left front view.

b. *Cabinet Assembly* (fig. 2). The cabinet assembly is fabricated of sheet metal. It serves as a housing for the counter chassis assembly and the flasher chassis assembly, both of which can be removed as separate units.

c. *Counter Chassis Assembly* (fig. 2). The counter chassis assembly is an electromechanical unit containing 15 counters. The counters record the hits made by the trainee upon the target(s) selected by the operator.

d. *Flasher Chassis Assembly* (fig. 2). The flasher chassis assembly is an electro-mechanical unit with 15 selector switches. These switches are operated manually by the operator of the target mechanism XM31 for selecting the target(s) to be fired upon. The switches can be operated in any desired sequence for either single or rapid fire.

e. *Terminal Box Assembly* (fig. 2). The terminal box assembly is provided with two color coded cables which connect to the counter chassis assembly and flasher chassis assembly. The plug connectors on the

cables provide a quick disconnect so that cabinet, counter chassis assembly, and flasher chassis assembly can be easily detached from the field wires (electrical telephone cable).

f. *Target Holder Assemblies* (fig. 2). The target holder assemblies are used to hold and emplace the target.

g. *Hit Switch Assemblies* (fig. 2). The hit switch assemblies consist of two sensitive switches attached to a cable. Clips on the switches permit the assembly to be attached to target holder assembly. The impact of the hits on the target activates the sensitive switches and relays to the counter the number of hits scored on the targets.

h. *Indicator Lights* (fig. 2). The indicator lights are mounted on the targets, one per target, and reveal the location of the target by flashes of light simulating gun fire.

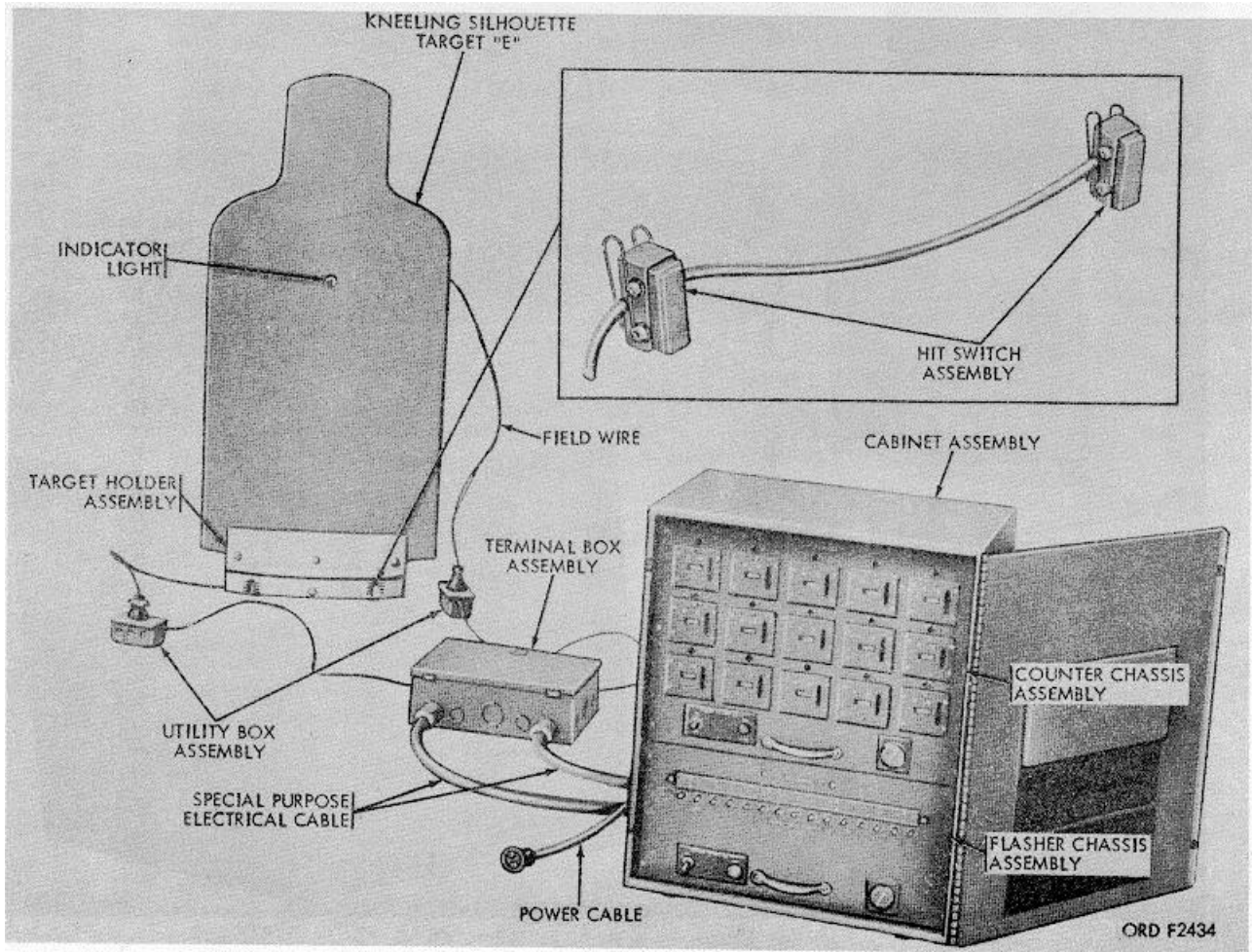

Figure 2. Night firing target mechanism XM31 - components and assemblies.

i. *Utility Box Assemblies* (fig. 2). The utility box assemblies are used as junction points from the hit switch assemblies (*g* above) and indicator lights (*h* above) on the targets to the terminal box assembly (*e* above).

5. Identification Plate

The identification plate (fig. 3) for target mechanism XM31 is riveted to upper center exterior surface of the door of the cabinet assembly.

6. Tabulated Data

a. Electrical System.

Power source 115 v ac

Lights:

Target indicator..... 24-28v, 0.50 amp

Counter chassis indicator..... 6-8 v, 0.15 amp

Flasher chassis panel 24-28v, 0.04amp

Fuses 3 amp

b. Dimensions and Weights.

	Weight (lb)	Length (in.)	Width (in.)	Height (in.)
Cabinet	44	21	14-7/16	23-7/16
Flasher chassis	17-1/2	19	13	8-3/4
Counter chassis....	29-1/2	19	13	14
Terminal box	15	12	8	4
Target holder.....	2	14-1/4	2-1/2	23-1/8
Utility box	1	4-3/16	2-3/8	2



Figure 3. Target mechanism XM31 identification plate

CHAPTER 2

OPERATING INSTRUCTIONS

Section I. SERVICE UPON RECEIPT OF MATERIEL

7. General

a. When new materiel is first received, it is the responsibility of the officer in charge to determine whether the materiel has been properly prepared for service by the supplying organization and to be sure it is in condition to perform its function.

b. All repair parts, tools, and equipment will be checked with the listing in appendix III and TM 9-6920-205-24P.

c. A record will be made of all missing parts, tools, equipment, and any malfunctions. Deficiencies will be corrected as quickly as possible.

8. Services

a. Visually check all components for evidence of damage or missing parts.

b. Inspect the identification on the door of the cabinet to make certain it is legible.

c. Check fuseholders to make certain the fuses are installed.

d. Check all cable connections to make certain that they mate securely with the receptacles.

e. Assemble and operate the target mechanism XM31 to detect any mechanical or electrical defects.

Section II. CONTROLS AND INSTRUMENTS

9. General

This section describes, locates, and illustrates the controls and instruments provided for operation of the target mechanism XM31.

10. Counter Assemblies (fig. 4)

The counter assemblies are electro-magnetic counters which record the number of hits made on the target. They are activated by the hit switches on the targets. The counter assemblies are mounted to the front panel of the counter chassis assemblies. There are three rows of five counters for a total of fifteen, one for each target. The counters are provided with reset knobs, which permit the operator to reset each counter to zero manually. Push upward on reset knob to set counters to zero. The counters are three digit counters ranging from 0 through 999.

11. Indicator Lights (fig. 4)

Indicator lights are mounted on the counter chassis panel, one light for each counter assembly. Indicator lights are also mounted on the targets, one light on each target (fig. 6). The light on the target flashes to simulate the flash of an enemy gun. The light(s) on the

panel will flash simultaneously with the light(s) on the target(s), which indicates to the operator that the circuit is operating correctly.

12. Power Toggle Switches (figs. 4 and 5)

There are two power toggle switches. Both the counter chassis assembly and the flasher chassis assembly are provided with a power toggle switch. The switches are located in the lower left corner of each chassis assembly. To turn the power on, flip the switch up.

13. Variable Resistors (figs. 4 and 5)

There are two variable resistors, one on each chassis assembly. The resistor on the counter chassis assembly controls the intensity of the illumination of the indicator lights on the panel. The resistor on the flasher chassis assembly controls the intensity of the illumination of the panel lights. The resistors are located in the lower right corner of the chassis assemblies. When knob of resistor is turned counterclockwise its full limit of travel, the circuit is open. Turning the knob clockwise closes the circuit and increases the intensity of the illumination of the lights.

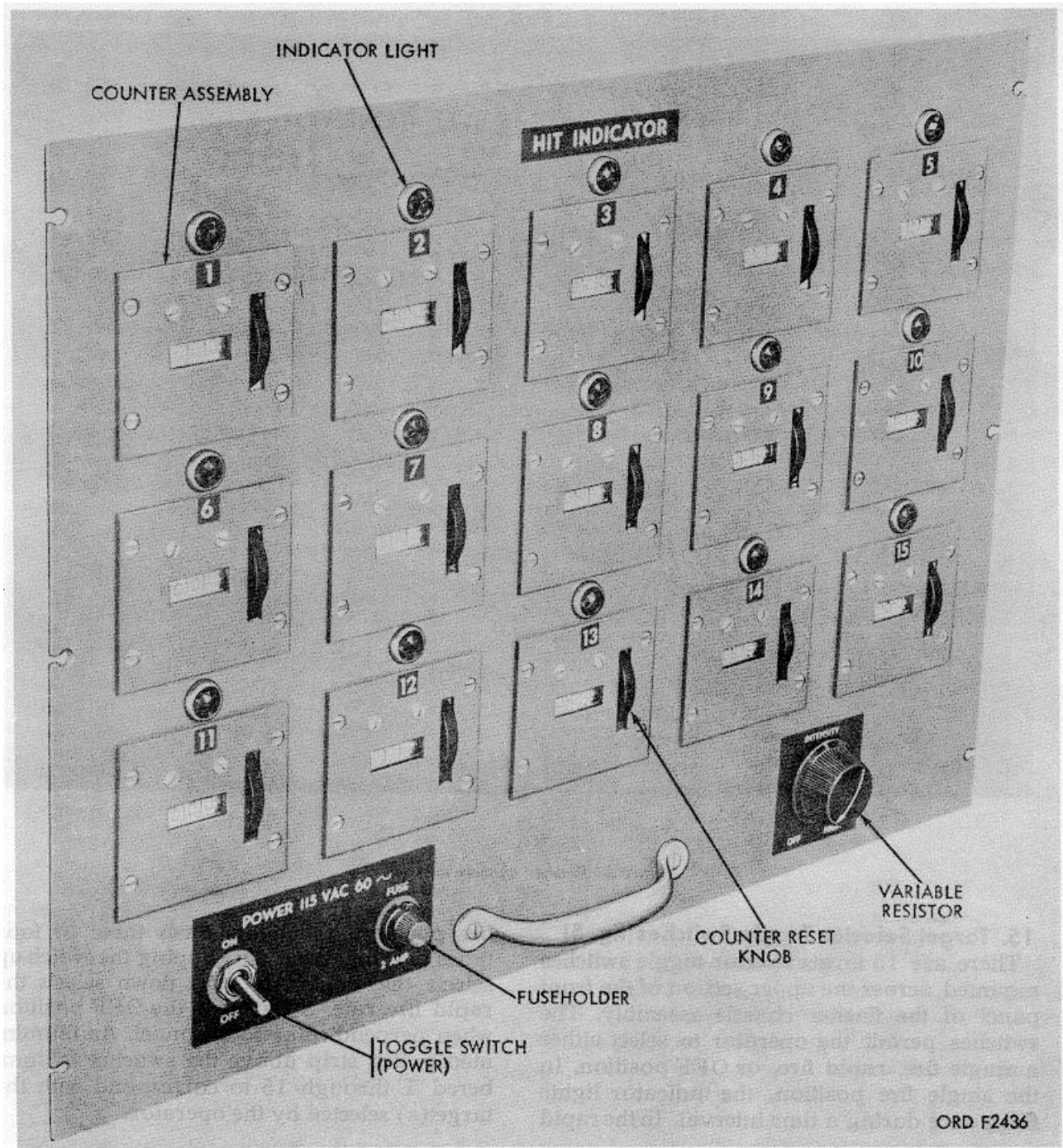

Figure 4. Counter chassis assembly.

14. Fuseholders (figs. 4 and 5)

There are two fuseholders. Each of the chassis assemblies, counter and flasher, is provided with a fuseholder. The fuseholders

contain the fuse for the 115-volt ac power source. They are located in the lower left section of each chassis. To remove fuse, turn the cap of fuseholder counterclockwise.

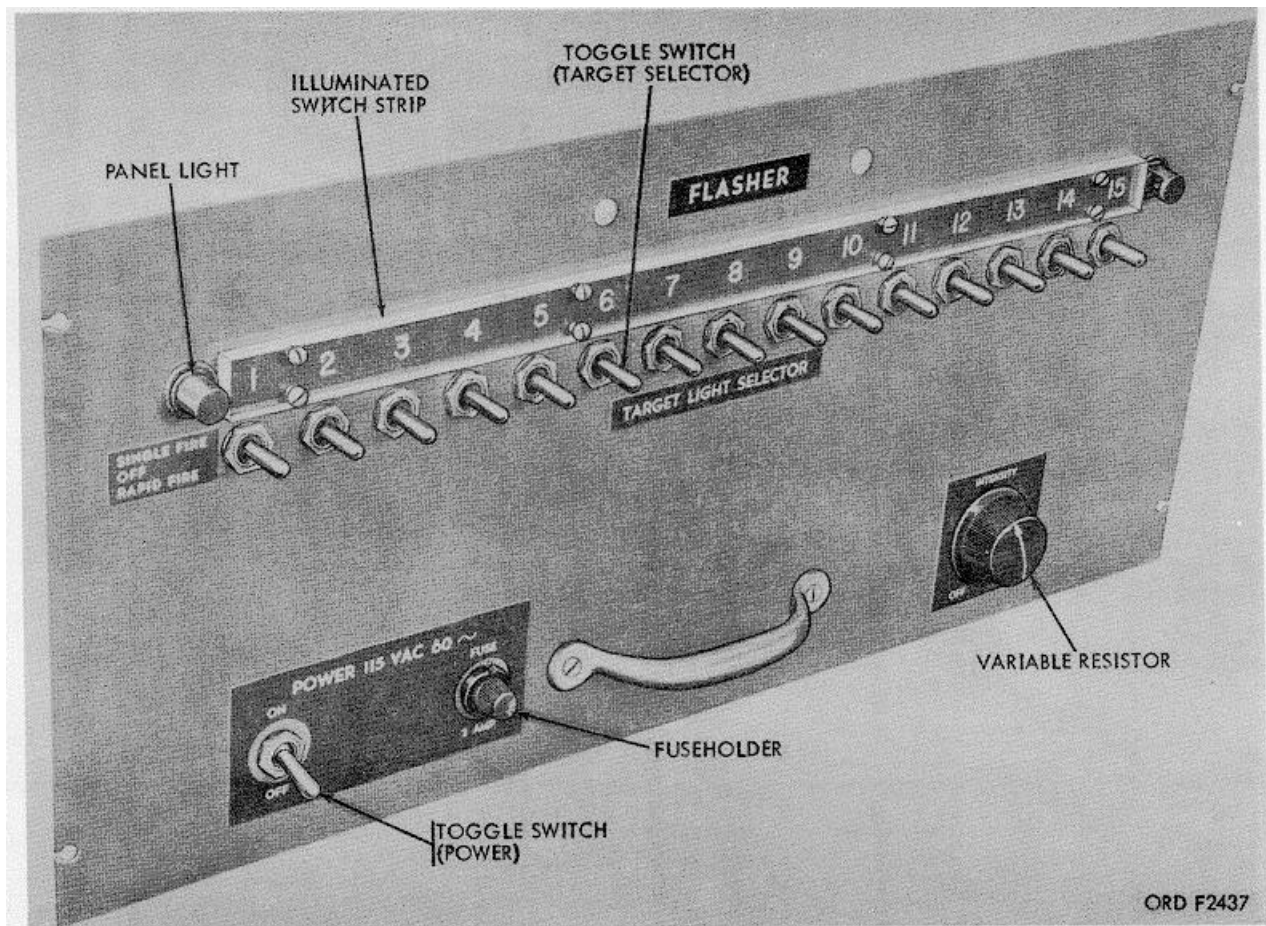

Figure 5. Flasher chassis assembly.

15. Target Selector Toggle Switches (fig. 5)

There are 15 target selector toggle switches mounted across the upper section of the front panel of the flasher chassis assembly. The switches permit the operator to select either a single fire, rapid fire, or OFF position. In the single fire position, the indicator lights flash once during a time interval. In the rapid

fire position, the lights flash three or four times per time interval. Flipping the switch up selects the single fire rate, down selects the rapid fire rate. Switch is in the OFF position when perpendicular to the panel. An illuminated switch strip above the switches is numbered 1 through 15 to correspond with the target(s) selected by the operator.

Section III. OPERATION UNDER USUAL CONDITIONS

16. Preparation for Operation

a. At each target install two utility box assemblies, as follows:

(1) Remove screws from covers of utility boxes and lift off the covers.

(2) Connect a field wire to each of the two receptacle connectors to each utility box.

Note. The distance between the target and the location of the flasher chassis and counter chassis assemblies will determine the length of the field wire necessary for each target. Field wire will be issued as CABLE, TELEPHONE, ELECTRICAL 6145 226-8807.

(3) Replace utility box covers and screws.

b. Install target indicator light as follows (fig. 6).

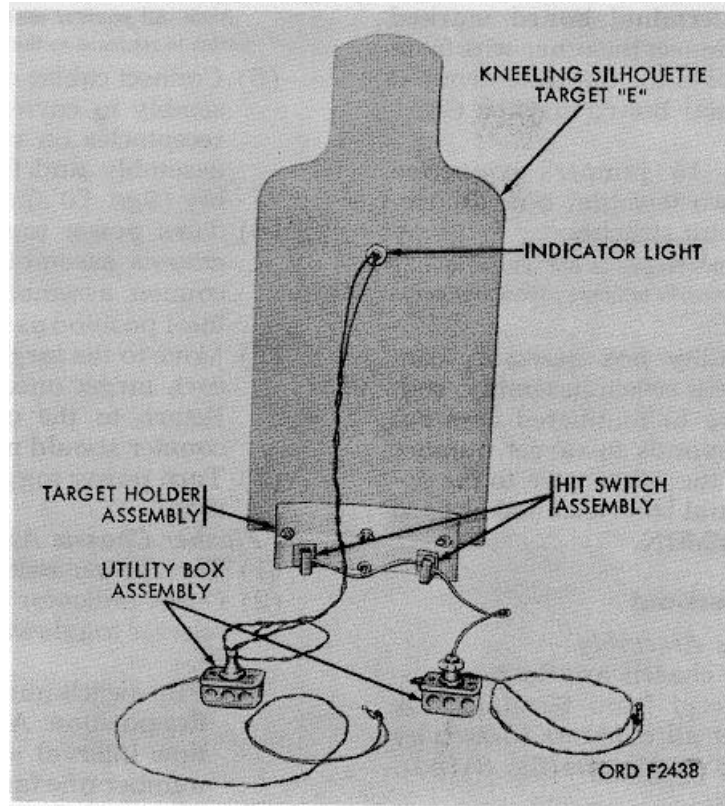

Figure 6. Target installation details - rear view.

- (1) Solder ends of two field wires to indicator light terminals.
- (2) Install indicator light in target.
- (3) Connect other ends of two field wires to terminals in receptacle plug connector.
- (4) Plug receptacle plug connector into utility box receptacle.

c. Clip the hit switch assembly to bottom edge of the target holder assembly. Position the assembly so that a switch is on each side of the rear of the target holder assembly (fig. 6). Plug the receptacle plug connector of hit switch assembly into the utility box assembly.

d. Run the two field wires from each utility box assembly to the terminal box assembly located in the area from which the target mechanism XM31 will be operated during firing.

e. Using a hammer and punch, remove knockouts, as necessary, to accept field wires from utility boxes (fig. 7).

f. Pull open the lid of the terminal box assembly and connect the field wires as follows:

- (1) From the utility box assembly connected to the indicator light on the target,

connected to the indicator light on the target, connect one field wire to number which corresponds to target

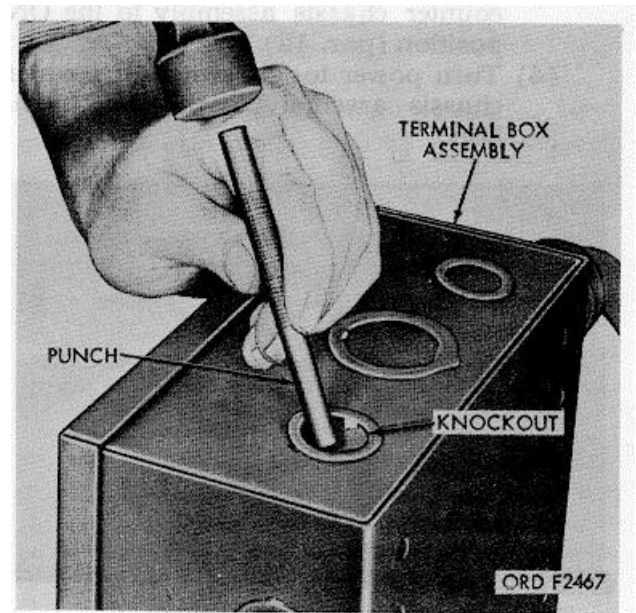

Figure 7. Removing knockout from terminal box assembly.

number on terminal board marked LIGHTS. Connect the other wire from the utility box to the opposite terminal on the terminal board marked COM MON.

- (2) Remove the 15 jumpers connected across the two terminal boards provided for the hit switches.

Note. If any of the targets is not utilized during the firing, do not remove jumpers corresponding to target number.

- (3) From the utility box assembly connected to the hit switch assembly, connect one wire to numbered terminal which corresponds to target number and connect the other wire to the opposite terminal on terminal board marked COMMON.

17. Operational Check-out

a. Counter Chassis Assembly.

- (1) With counter chassis and flasher chassis disconnected from terminal box assembly, set all counters to zero by operating the reset knobs (fig. 8) (par. 10).
- (2) Plug the counter chassis electrical power cable (fig. 9) into the 115-volt ac power source. Also connect electrical power cable from flasher chassis assembly (fig. 9) to receptacle connector in counter chassis assembly.
- (3) Turn the power toggle switch of the counter chassis assembly to the ON position (par. 12).
- (4) Turn power toggle switch of counter chassis assembly to the OFF position.

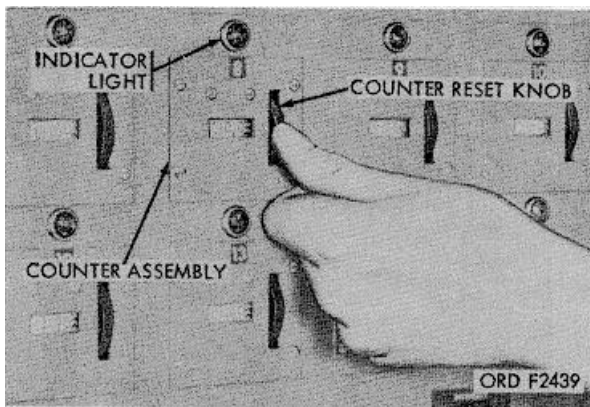

Figure 8. Operating counter reset knob.

Note. All counter assemblies should register 1 as switch is returned to the OFF position.

- (5) Connect cables of the terminal box assembly to corresponding color coded receptacles on rear of counter chassis assembly and flasher chassis assembly (figs. 10 and 11).
- (6) Turn power toggle switch of counter chassis assembly to ON position. All counter assemblies should remain on the 1 position as recorded in (4) above.
- (7) Move to the target area and lightly tap each target once with finger or stick. Return to the counter chassis. Each counter should now read 2.
- (8) Turn power toggle switch to OFF position.

b. Flasher Chassis Assembly.

- (1) Turn power switch to the ON position.
- (2) Check indicator lights by use of target selector toggle switches (par. 15) (fig. 5).
 - (a) Flip switch number one to the single fire position. A single flash at a given time interval should appear on the number one target.
 - (b) Move switch number one to the rapid fire position. Three or four flashes at a given time interval should appear on the number one target.
 - (c) Continue to check, one at a time, switches two through fifteen for single fire position (a) above and for rapid fire position (b) above.
- (3) Flip power switch to the OFF position.

18. Operation

a. Operate counter reset knobs of the counter assemblies (par. 10) and set all counters to zero (fig. 8).

b. Place power toggle switch on counter chassis assembly to the ON position (par. 12).

c. Place power switch on flasher chassis assembly to the ON position (par. 12).

d. Operate the variable resistors (par. 13) to turn on and to adjust the intensity of illumination required for the target indicator lights and the panel lights (fig. 12 and 13).

e. Operate target selector toggle switches (par. 15) for single or rapid fire and for any sequence as to the order in which targets are to be fired upon by the trainee.

f. Record the number of hits made by the trainee on each target as registered on the counter assemblies (par. 10).

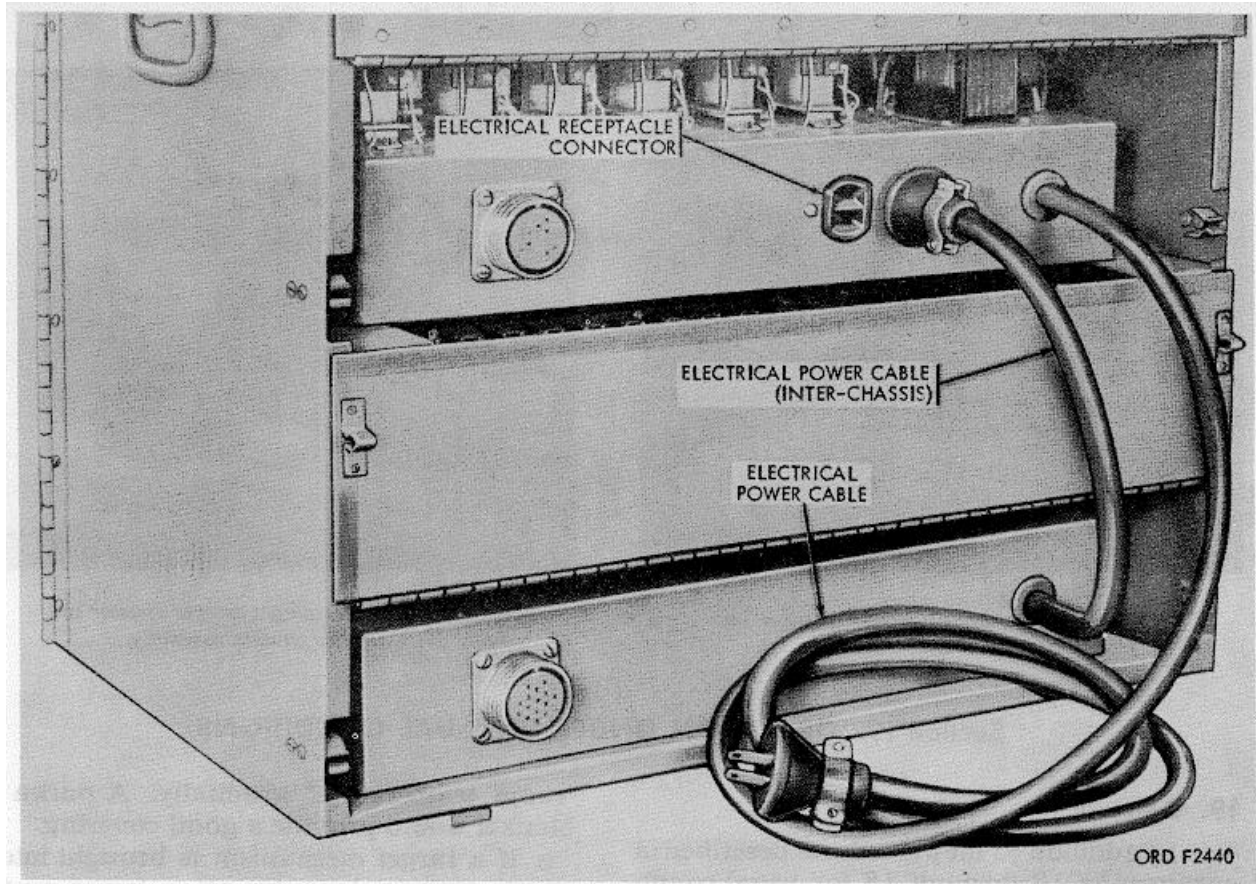

Figure 9. Counter and flasher chassis electrical power cables.

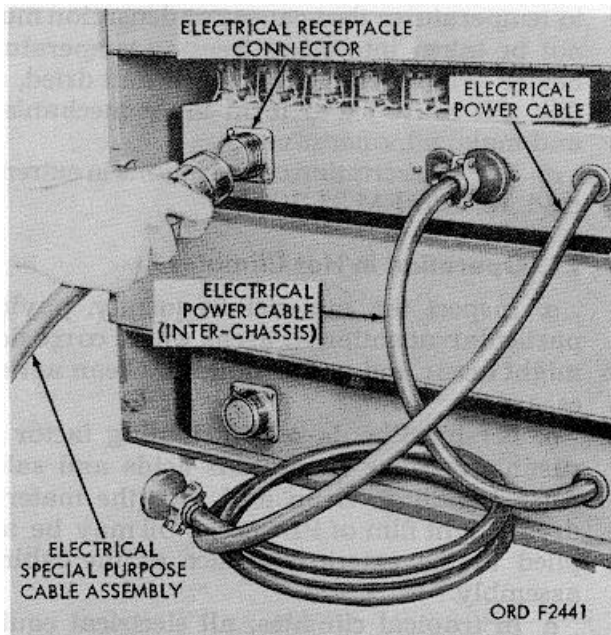

Figure 10. Connecting cable assembly to electrical receptacle connector in counter chassis assembly.

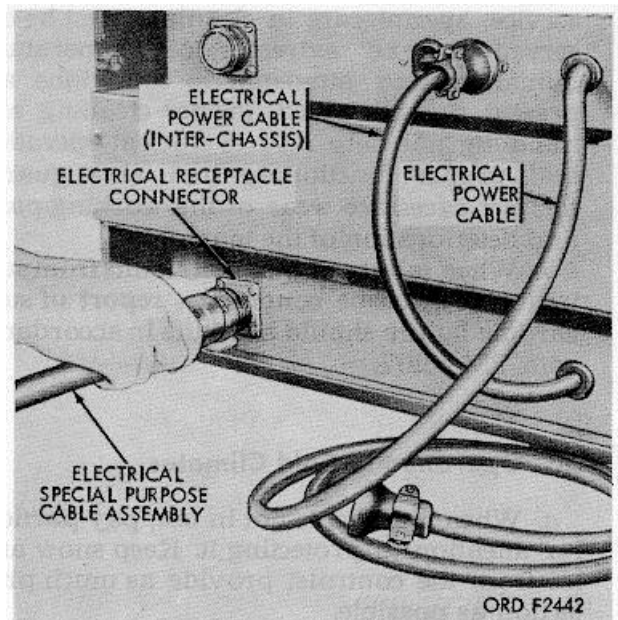

Figure 11. Connecting cable assembly to electrical receptacle connector in flasher chassis assembly.

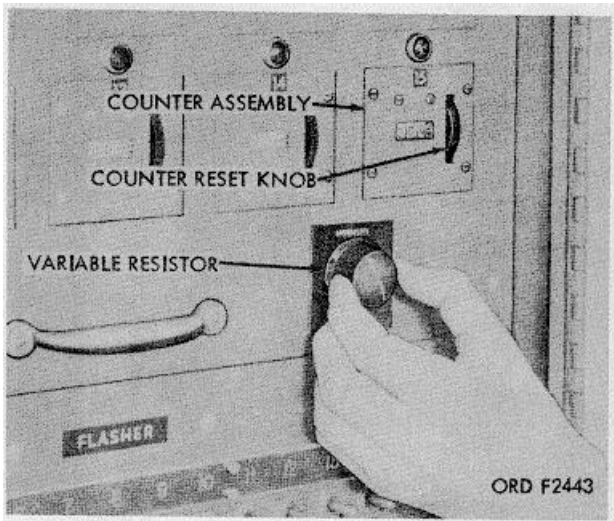

Figure 12. Operating variable resistor on counter chassis assembly.

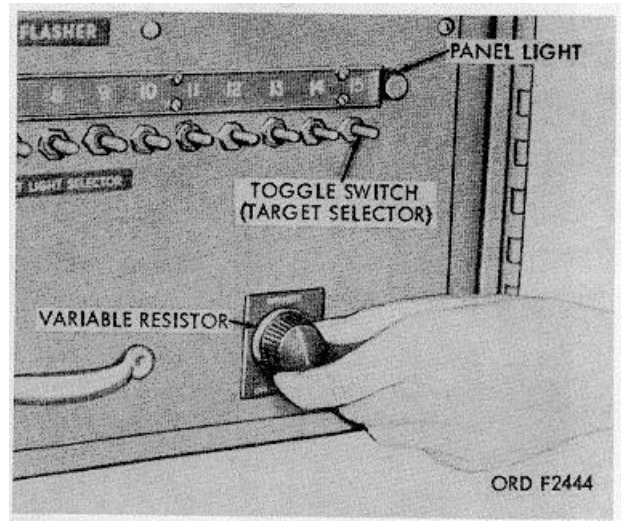

Figure 13. Operating variable resistor on flasher chassis assembly.

Section IV. OPERATION UNDER UNUSUAL CONDITIONS

19. General

a. In addition to the procedures described in paragraphs 16 through 18 for usual conditions, special instructions for servicing the target mechanism XM31 under unusual conditions are contained or referred to herein. In addition to the usual preventive-maintenance service, special care in cleaning must be observed where extremes of temperature, humidity, and atmospheric conditions are present or anticipated. Proper cleaning and handling not only insures efficient operation and proper functioning but also guards against excessive wear of the working parts and deterioration of the materiel.

b. When failure of materiel results from subjection to extreme conditions, report of such chronic failure should be made in accordance with TM 9-207.

20. Operation in Cold Climates

a. When materiel is not in use, pay particular attention to protecting it. Keep snow and ice from the controls; provide as much protection as possible.

b. When the target mechanism XM31 is brought from cold outdoor temperature to a heated area, it should be wrapped in a covering of sufficient thickness to allow it to reach "room blanket would provide a good covering.

c. If a target mechanism is brought into a warm area and condensation forms on the surface of the metal, it must be thoroughly cleaned and dried as soon as it reaches room temperature. A target mechanism introduced to temperatures that cause condensation must not be taken into below freezing temperature before it is thoroughly cleaned and dried, as this will cause ice to form in the mechanism and make it inoperative.

d. For a description of operations in extreme cold, refer to FM 31-70.

21. Operation in Hot Climates

a. Inspect the materiel frequently, paying particular attention to areas where corrosion might occur and not be noticed. Clean as necessary.

b. Perspiration is a contributing factor to rusting because it contains acids and salts. After handling, clean and wipe the materiel dry. A light Mm of PL special oil may be applied to the exterior surface of the cabinet assembly.

c. In tropical climates, all electrical equipment must be checked frequently. Fungus growth attacks insulation and accelerates breakdown. Presence of moisture will contribute to voltage leaks.

CHAPTER 3

ORGANIZATIONAL MAINTENANCE INSTRUCTIONS

Section I. REPAIR PARTS, TOOLS, AND EQUIPMENT

22. General

Repair parts, tools, and equipment are issued to the using organization for operating and maintaining the target mechanism XM3 1. Tools and equipment should not be used for purposes other than prescribed and, when not in use, should be properly stowed.

23. Repair Parts

Repair parts are supplied to the using organization for replacement of those parts most likely to become worn, broken, or otherwise unserviceable, providing replacement of those parts is a function of the using organization. No repair parts are supplied to the first echelon.

Repair parts supplied to the second echelon are listed in TM-9-6920-205-24P which is the authority for requisitioning replacements.

24. Common Tools and Equipment

Common tools and equipment having general application to this materiel are authorized by tables of allowances and tables of organization and equipment.

25. Special Tools and Equipment

No special tools or equipment specially designed for first or second-echelon maintenance are supplied or required for the target mechanism XM31.

Section II. PREVENTIVE-MAINTENANCE SERVICES

26. General

The purpose of preventive-maintenance services is to detect first signs of electrical and mechanical failures of components in the materiel and to insure that appropriate corrective action is taken before expensive and time-consuming repairs or replacements are required. The system of preventive-maintenance services is based on frequent inspection and services accomplished by operator and organizational maintenance personnel under active supervision by all commanders and leaders.

27. Responsibility

The operator is personally responsible for assigned materiel. Squad, section, and platoon leaders are charged with supervisory responsibility for materiel pertaining to their commands. Unit and organization commanders are required to insure that materiel issued or assigned to their commands is properly maintained in a serviceable condition, and is properly cared for and used.

28. Services and Inspections

The following general procedures apply to preventive-maintenance services and to all inspections

and are just as important as the specific procedure.

a. Inspect the target mechanism XM31 to see that it is correctly assembled. This is a visual inspection to see if the components of the mechanism are in their normal position, and if all parts are present and in their correct relative positions.

b. Inspect for loose, broken, or damaged parts. Loose parts will be tightened. Broken or damaged parts will be repaired or replaced by the echelon of maintenance as shown in the maintenance allocation chart of appendix II.

c. Any defect or unsatisfactory operating characteristic noted before, during, or after operation of the materiel, beyond the scope of the operator, will be reported to the designated individual in authority at the earliest opportunity.

29. Schedule of Preventive Maintenance

a. Purpose. To insure electrical and mechanical efficiency, it is necessary that the materiel be systematically inspected at regular intervals, so that defects may be discovered and corrected before they result in serious damage

or failure. Certain scheduled maintenance services or unsatisfactory operating characteristics beyond the scope of the operator to correct must be reported at the earliest opportunity to the designated individual in authority.

b Schedule. The items or points to be inspected and serviced by the operator are listed in table I.

Table I. Preventive-Maintenance Services by Operator

Intervals					PROCEDURE
B	D	A	W	M	
X	X	<i>Switches.</i> Check all switches for mechanical freedom. If switches do not function properly, notify Ordnance maintenance personnel.
X	X	<i>Fuses.</i> Inspect visually for blown fuse. If fuse is blown, notify organizational maintenance personnel.
X	X	<i>Variable resistors.</i> Check for loose knobs and freedom of movement. If not operating properly, notify Ordnance maintenance personnel.
X	X	<i>Indicator lights.</i> Check for broken or missing lamps or lens caps. If lamps are burned out or missing or if lens caps are broken or missing, notify Ordnance maintenance personnel.
X	X	<i>Receptacles.</i> Check for damaged receptacles on chassis assemblies and utility boxes. If damaged, notify Ordnance maintenance personnel.
X	X	<i>Target indicator lights.</i> Check for broken or burned out lamps. If lamps are broken or burned out, notify organizational maintenance personnel.
XX	<i>Terminal box.</i> Check for improperly assembled field wire connections or loose connections, and broken wires. Correct any deficiencies found.
XX	<i>Counters.</i> Check all counters for mechanical freedom. Report any failures to Ordnance maintenance personnel.
XX	..X	<i>Hit switch assembly.</i> Check hit switches for proper operation. Report any failures to Ordnance maintenance personnel.
XX	<i>Field wire.</i> Check for broken wire. If wire is broken, notify organizational maintenance personnel.

30. Preventive Maintenance by Organizational Maintenance Personnel

a. Service by organizational maintenance personnel includes a systematic check to see that all operators preventive maintenance has been properly performed at the prescribed intervals and that the materiel is in the best possible operating condition. The services set forth in table II are to be performed or

supervised by organizational maintenance personnel or supporting maintenance personnel at the designated intervals, in addition to any maintenance required as a result of the checks and services by the operator. The frequency of the preventive-maintenance services prescribed is considered a minimum requirement for operation of the materiel under usual conditions. Under unusual operating condition, such as extreme temperatures, extremely wet terrain,

etc., it will be necessary to perform the maintenance services more frequently.

b. The operator should have the materiel in a reasonably clean condition for scheduled maintenance service by organizational maintenance personnel.

Table II. Preventive-Maintenance Services by Organizational Maintenance Personnel

INTERVAL			PROCEDURE
W	B	S	
X	X	<i>Switches.</i>
		Check all switches for freedom of movement and proper functioning. If switches do not function properly, notify Ordnance maintenance personnel.
X	X	<i>Fuses.</i>
		Check fuses for continuity. Replace if necessary (par. 32).
X	X	<i>Variable resistors.</i>
		Check for loose knobs. Operate resistors. If not operating properly, notify Ordnance maintenance personnel.
X	X	<i>Indicator lights.</i>
		Check for burned out or missing lamps. Replace as needed (par. 33). Check for missing or broken lens caps. If replacement is needed, notify Ordnance maintenance personnel.
X	X	<i>Receptacles.</i>
		Check for damaged receptacles in chassis assemblies and utility boxes. Report damaged receptacles to Ordnance maintenance personnel.
X	X	<i>Target lights,</i>
		Check for burned-out or broken lamps. Replace as required. Check for damaged indicator lights and field wire. Replace as required (par. 33).
X	X	<i>Terminal box.</i>
		Inspect terminals and terminal boards for loose connections. Clean corrosion deposits from all electrical terminals.
X	X	<i>Counter assembly.</i>
		Check all counters for mechanical freedom and electrical operation. Report any failures to Ordnance maintenance personnel.
X	X	<i>Hit switch assembly.</i>
		Check for broken or damaged switches to wire. Report any damaged or impaired switches to Ordnance maintenance personnel.
X	X	<i>Field wire.</i>
		Check for broken wire. Repair as required.

Section III. REPLACEMENT OF ORGANIZATIONAL REPAIR PARTS

31. Scope

The using organization is limited to the replacement of the following items:

- a. Fuses in the fuseholders of the counter chassis and flasher chassis assemblies.
- b. Lamps in panel lights of flasher chassis assembly, in lamp holders of each counter assembly in the counter chassis assembly, and in each indicator light attached to the targets.
- c. Indicator lights installed in the targets.

d. Receptacle plug connectors attached to hit switch assembly cable and field wires attached to target indicator light

32. Fuses

To replace a blown fuse in either of the fuse holders mounted in the counter chassis or flasher chassis assemblies (fig. 14) proceed as follows;

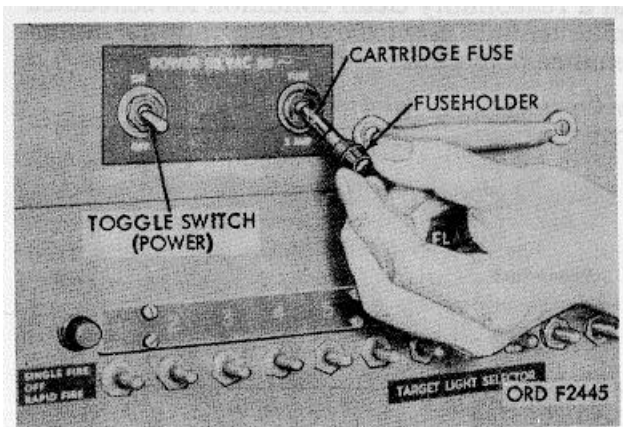

Figure 14. Removing or installing cartridge fuse.

- a. Make sure power switches are in OFF position.
- b. Unscrew the fuse holder from the front panel by turning it counterclockwise.
- c. Pull faulty fuse from cap of fuse holder and discard fuse.
- d. Insert new fuse 5920-010-6652 into cap.
- e. Insert fuse holder with fuse attached into opening in panel and screw fuse holder clockwise until it is tight.

33. Lamps and Indicator Lights

a. Flasher Chassis Assembly.

- (1) Place power switch in the OFF position.
- (2) Unscrew knurled cap of panel light (fig. 15) by turning it counterclockwise.
- (3) Remove burned out lamp from end of cap and insert new lamp 6240-1557836 into cap.
- (4) Insert cap into panel light socket and secure by turning it clockwise until tight.

b. Counter Chassis Assembly

- (1) Place power switch in the OFF position.

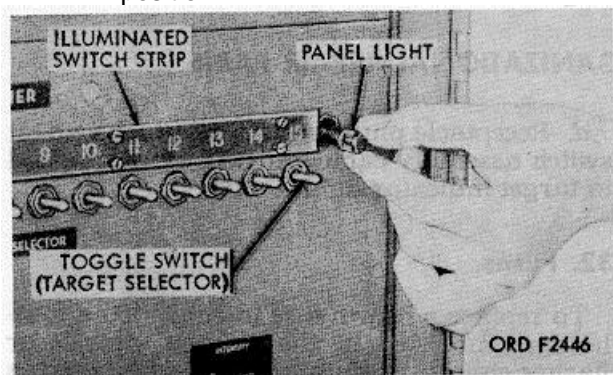

Figure 15. Removing or installing panel light

- (2) Remove three screws from each side of top rear panel of the cabinet assembly, and remove top rear panel.
- (3) Exert a slight pressure upon burned out lamp to force it into socket and then remove by turning it counterclockwise (fig. 16).
- (4) Install new lamp 6240-155-8706 into light socket by inserting base of lamp into socket, as far as it will go, turn it clockwise and release pressure on lamp.

c. Target

- (1) Replace lamp as follows:

- (a) Pull plug connector of indicator light from utility box at target.

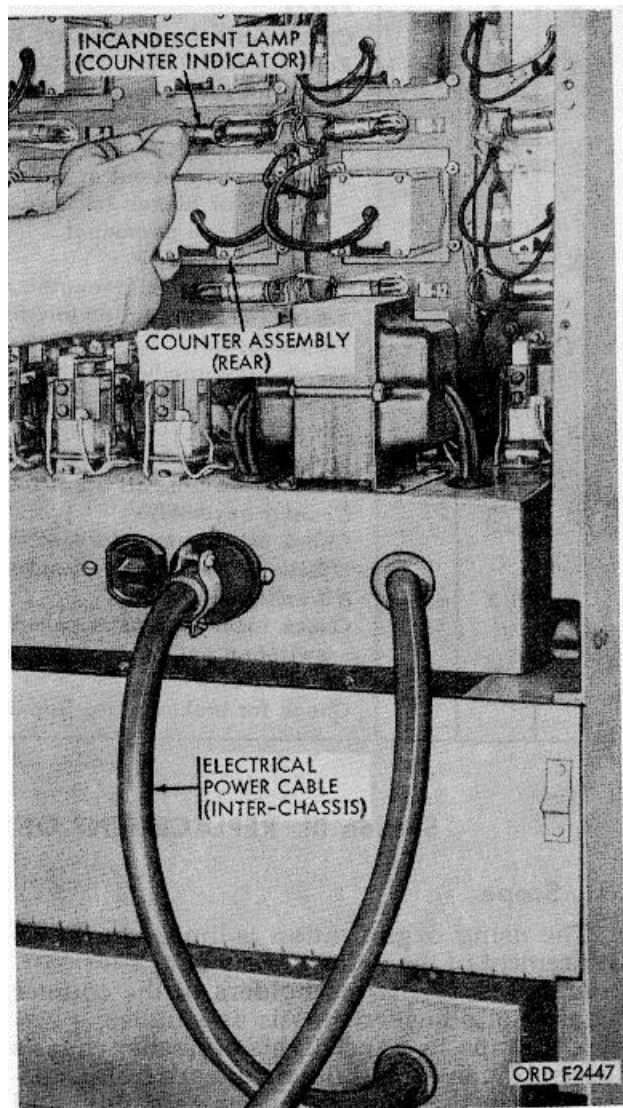

Figure 16. Removing or installing counter indicator light lamp.

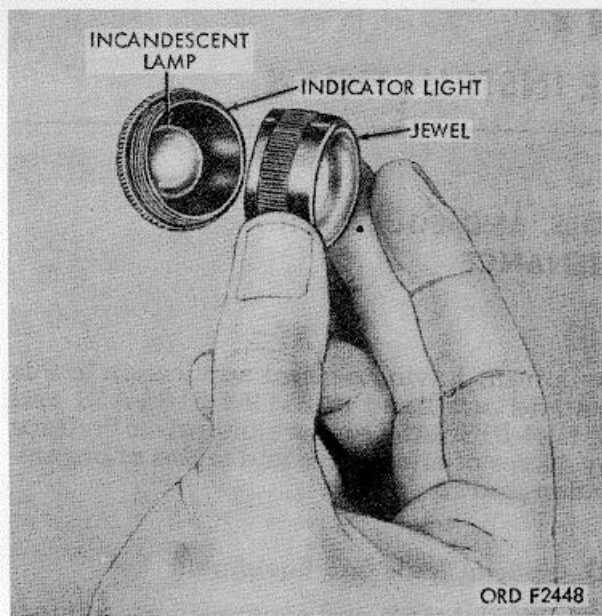

Figure 17. Removing or installing jewel in target indicator light.

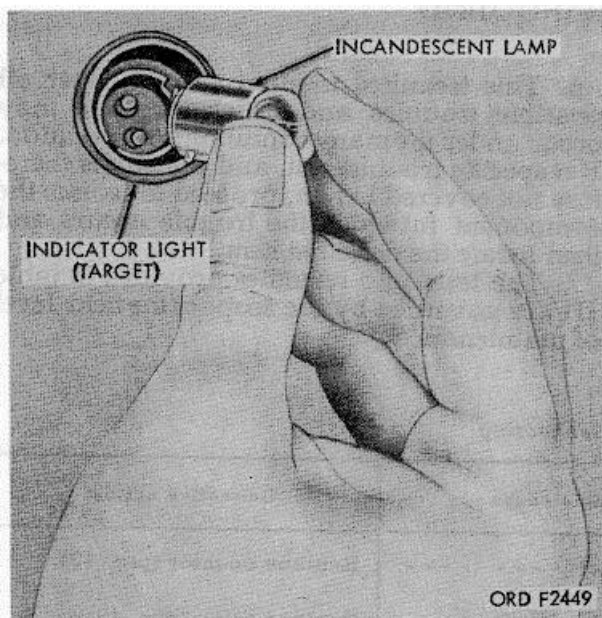

Figure 18. Removing or installing target indicator light lamp.

- (b) Unscrew jewel lens from body of indicator light and remove (fig 17).
 - (c) Push in on lamp and turn it counterclockwise to remove burned out lamp (fig. 18).
 - (d) Insert base of new lamp 6240-1557926 into body of indicator light and turn it clockwise to secure.
 - (e) Screw jewel onto body of indicator light
- (2) Replace indicator light as follows:
 - (a) Remove defective indicator light from target (fig. 19).
 - (b) Cut or unsolder wire at terminals of defective indicator light
 - (c) Solder wires to terminals of new indicator light
 - (d) Install new indicator light 6210-8506897 in target.
- d. *Receptacle Plug Connectors.* Replace receptacle plug connectors as follows:
- (1) Disconnect wires from terminals of defective receptacle plug connector 5935259-1818.
 - (2) Connect wires to terminals of new receptacle plug connector.

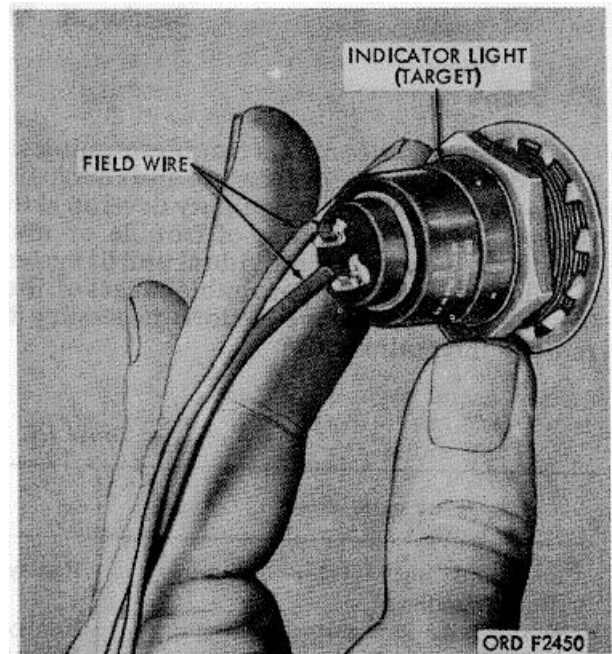

Figure 19. Removing or installing target indicator light

CHAPTER 4

FIELD MAINTENANCE INSTRUCTIONS

Section I. PARTS, SPECIAL TOOLS, AND EQUIPMENT FOR FIELD MAINTENANCE

34. General

Tools, equipment, and maintenance parts over and above those available to the using organization are supplied to Ordnance field maintenance units shops for maintaining, repairing, and/or rebuilding the materiel.

having general application to this materiel are listed in SM9-4-5180-A18 and SM 9-4-5180-A57 and are authorized for issue by tables of allowances and tables of organization and equipment 37. Special Tools and Equipment No special tools and equipment are authorized for use.

35. Parts

Field maintenance repair parts are listed in TM 9-6920-205-24P which is the authority for requisitioning replacements.

38. Improvised Tools

No improvised tools are authorized for use.

36. Common Tools and Equipment

Standard and commonly used tools and equipment

Section II. TROUBLESHOOTING

39. Scope

a. This section contains troubleshooting information and tests for locating and correcting some of the troubles which may develop in the materiel. Each symptom of trouble or malfunction given for an individual unit or system is followed by a list of probable causes of the trouble and corrective actions necessary to remedy the malfunction.

b. This technical manual cannot cover all possible troubles and deficiencies that may occur under the many conditions of operation. If a specific trouble, test, and remedy is therefore not covered herein, proceed to isolate the component in which the trouble occurs and then locate the defective item.

c. The tests and remedies provided in table III are governed by the scope of the field level of maintenance.

Table 111. Troubleshooting

Malfunction	Probable cause	Corrective action
Counters do not register w/counter light flashing.	Faulty counter	Replace counter (par. 42).
Counter fails to register and counter light does not flash.	Faulty relay	Replace relay (par. 42).
	Burned out bulb	Replace bulb (par. 33).
	Faulty counter	Replace counter (par. 42).
Counter fails to register during operational check.	Faulty relay	Replace relay (par. 42).
	Faulty counter	Replace counter (par. 42).
Counters register during operational checkout.	Loose connections or broken	Tighten connections. Replace defective wires.
	field wires.....	
	Faulty hit switch.....	Replace hit switch (par. 47).

Table 111. Troubleshooting

Malfunction	Probable cause	Corrective action
Target light fails to flash when corresponding numbered switch on flasher chassis is on the ON, single position fire'.	Burned out bulb in target light assembly. Loose connections or broken field wires.	Replace bulb (par. 33). Check connections and wires.
Target light fails to flash when corresponding numbered switch on flasher chassis is on the ON, position rapid fire.	Faulty capacitor Faulty timing motor Faulty fuse Burned-out bulb in target light assembly. Loose connections or broken field wires.	Replace capacitor (par. 43). Replace timing motor (par. 43). Replace fuse (par. 32). Replace bulb (par. 33). Check connections and wires.
Counter does not register when hit on target is simulated during operational checkout procedure.	Faulty timing motor Faulty fuse Faulty hit switch..... replace hit switch (par. 47).	Replace timing motor (par. 43). Replace fuse (par. 32). Check for open switch or

Section III. REPAIR OF CABINET ASSEMBLY, COUNTER CHASSIS ASSEMBLY, AND FLASHER CHASSIS ASSEMBLY

40. General

This section contains the removal, disassembly, repair, assembly, and installation necessary for field maintenance of the cabinet, counter chassis, and flasher chassis assemblies.

41. Cabinet Assembly

Repair of the cabinet assembly is limited to the replacement of the bail handles on each side the flush catches, and their attaching hardware, and to the replacement of other nuts, screws, and washers, if necessary.

Note. The key numbers shown below* in parentheses refer to figure 20.

a. Removal of Bail Handles. Remove four machine screws (2), four lockwashers (3), and four plain nuts (4) securing bail handles (1) to sides of cabinet. Remove bail handles.

b. Removal of Flush Catches. Remove 12 machine screws (5), 12 lockwashers (6), and 12 plain nuts (7) securing flush catches (15) to inner sides of cabinet. Remove flush catches.

c. Inspection and Repair.

- (1) Inspect the rear of the cabinet for any missing or damaged screws securing the two rear panel assemblies (13 and 14) to

the cabinet. Replace screws, as necessary, using machine screw(5).

- (2) Inspect the screws and washers securing the cabinet legs (11) to the bottom of the cabinet. If screws or washers are missing or damaged, replace as necessary with screws (9) and washers (10).
- (3) Inspect the screws, nuts, and washers securing the door 'pull (8) to the door panel assembly. If any of the attaching hardware is missing or damaged replace as necessary, using machine screw (5), lockwasher (6), and plain nut (7).
- (4) Inspect the screws, nuts and washers securing the hinge of the door panel assembly (12). If any of the attaching hardware is missing or damaged replace as necessary using plain nut (7), machine screw (5), and lock washer (6).

d. Installation of Bail Handles. Position bail handles (1) on sides of cabinet and install four machine screws (2), four lockwashers (3), and four plain nuts (4).

e. Installation of Flush Catches. Position flush catches (15) on inner sides of cabinet and install 12 machine screws (5), 12 lockwashers (6), and 12 plain nuts (7).

42. Counter Chassis Assembly

a. General.

The counter chassis assembly consists of the following items: 16 relays, 15

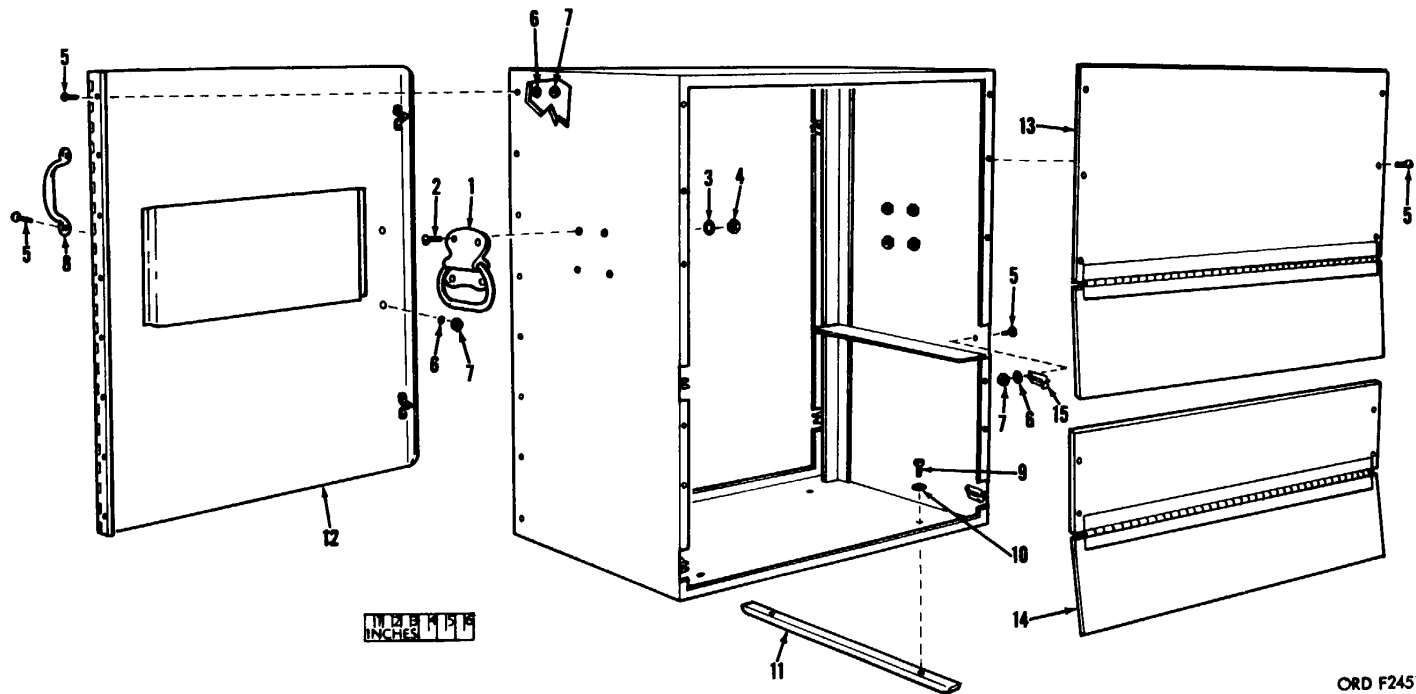

- 1-Bail handle 5340-827-2796
- 2-Machine screw 5305-514-7702
- 3-Lockwasher 5310-209-5306
- 4-Hexagon plain nut 5310-012-0361

- 5-Machine screw 5305-579-3019
- 6-Lockwasher 5310-596-7674
- 7-Hexagon plain nut 5310-176-8133
- 8-Door pull 7545950

- 9-Hexagon-head capscrew 5305-688-2021
- 10-Lockwasher 5310-043-5862
- 11-Cabinet leg 7546163
- 12-Door panel assembly 7545978

- 13-Rear panel assembly 7545975
- 14-Rear panel assembly 7545971
- 15-Flush catch 6920-864-2923

Figure 20. Cabinet assembly - partial exploded view.

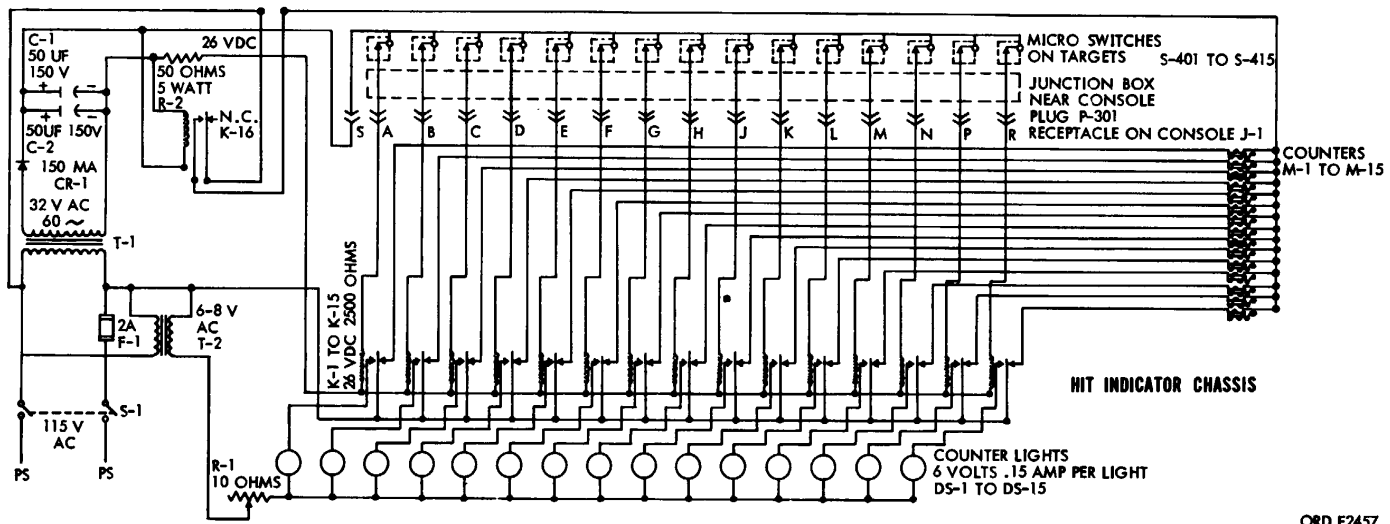

ORD F2457

Figure 21. Counter chassis assembly - schematic diagram

counter assemblies, 2 step-down transformers, rectifier, variable resistor, fuse-holder, power switch, receptacle connector, capacitors, wiring harness, and miscellaneous electronic parts and attaching hardware. For a schematic diagram of the counter chassis assembly, refer to figure 21.

b. Disassembly.

- (1) From both sides of front panel of counter chassis assembly, remove six machine screws (1, fig. 22) securing chassis in cabinet assembly. Using the handle on the chassis, pull out and remove the counter chassis assembly.
- (2) Unsolder terminal leads of step-down transformer (2, fig. 22), and remove four plain nuts (3, fig. 22), four lockwashers (4, fig. 22), and four machine screws (1, fig. 22). Remove transformer.
- (3) Unsolder terminal wires at relay (5, fig. 22) and remove two machine screws (6, fig. 22) and two lockwashers (4, fig. 22). Remove relay.
- (4) Unsolder wire leads at electrical counter (7, fig. 22). Remove four plain nuts (8, fig. 22), four lockwashers (9, fig. 22), and four machine screws (10, fig. 22). Remove counter.
- (5) Unsolder wires at terminal leads of indicator light (11, fig. 22) and terminal board (13, fig. 22). Remove terminal board by removing screw of counter (see (4) above). Remove indicator light by unscrewing mounting nut on its base. Push in on incandescent lamp (12, fig. 22), turn counterclockwise, and remove.
- (6) Unsolder wire at terminals of receptacle connector (14, fig. 22). Remove four plain nuts (3, fig. 22), four lockwashers (4, fig. 22), and four machine screws (1, fig. 22). Remove connector.
- (7) Unsolder connections on power toggle switch (1, fig. 23) and remove the switch by unscrewing the mounting nut.
- (8) Disconnect terminals of two fixed capacitors (2, fig. 23) from the terminal board and unsolder terminal leads from the capacitors. Remove capacitors.
- (9) Unsolder wires at terminals of fuse holder (3, fig. 23) and unscrew mounting nut from front of fuse holder. Pull fuse holder from panel. Unscrew cap of fuse holder by turning counterclockwise, and remove cartridge fuse (4, fig. 23).

- (10) Unsolder wires on variable resistor (5, fig. 23) and loosen small setscrew in knob of resistor. Pull knob from shaft and remove mounting nut. Remove resistor from the panel.
- (11) Disconnect all lug terminals (6 and 7, fig. 23) from terminal board (8, fig. 23) and remove four plain nuts (9, fig. 23), four lockwashers (10, fig. 23) and four machine screws (11, fig. 23) in ends of the terminal board. Remove terminal board.
- (12) Disconnect lug terminals (12 and 13, fig. 23) at receptacle connector (14, fig. 23) and remove two plain nuts (9, fig. 23), two machine screws (15, fig. 23), and two lockwashers (10, fig. 23) securing connector to chassis. Remove connector.
- (13) Remove cable clip (16, fig. 23) from electrical power cable.
- (14) Remove clamp from electrical plug connector of power cable and disconnect wire from terminals of plug. Remove electrical plug connector (17, fig. 23) from power cable. Remove rubber grommet (19, fig. 23) from chassis and cable.
- (15) Remove electrical power cable (18, fig. 23) from counter chassis assembly.
- (16) Disconnect leads from step-down transformer (20, fig. 23) and remove two plain nuts (9, fig. 23), two lockwashers (10, fig. 23), and two machine screws (21, fig. 23). Remove transformer.
- (17) Unsolder leads to metallic rectifier (22, fig. 23) and remove plain nut (9, fig. 23), lockwasher (10, fig. 23), and machine screw (23, fig. 23). Remove rectifier.
- (18) Remove two plain nuts (9, fig. 23), two lockwashers (10, fig. 23), and two machine screws (24, fig. 23) securing door pull (25, fig. 23) to counter chassis assembly.

c. Inspection.

- (1) Visually inspect all wiring and insulation covering for evidence of shorts, insulation breakdown, or abrading away of protective coverings.
- (2) Inspect to see if all components are securely installed.
- (3) Inspect all mounting threads of components for stripping, marring, or crossed threads.
- (4) Inspect transformer for evidence of potting compound leakage.

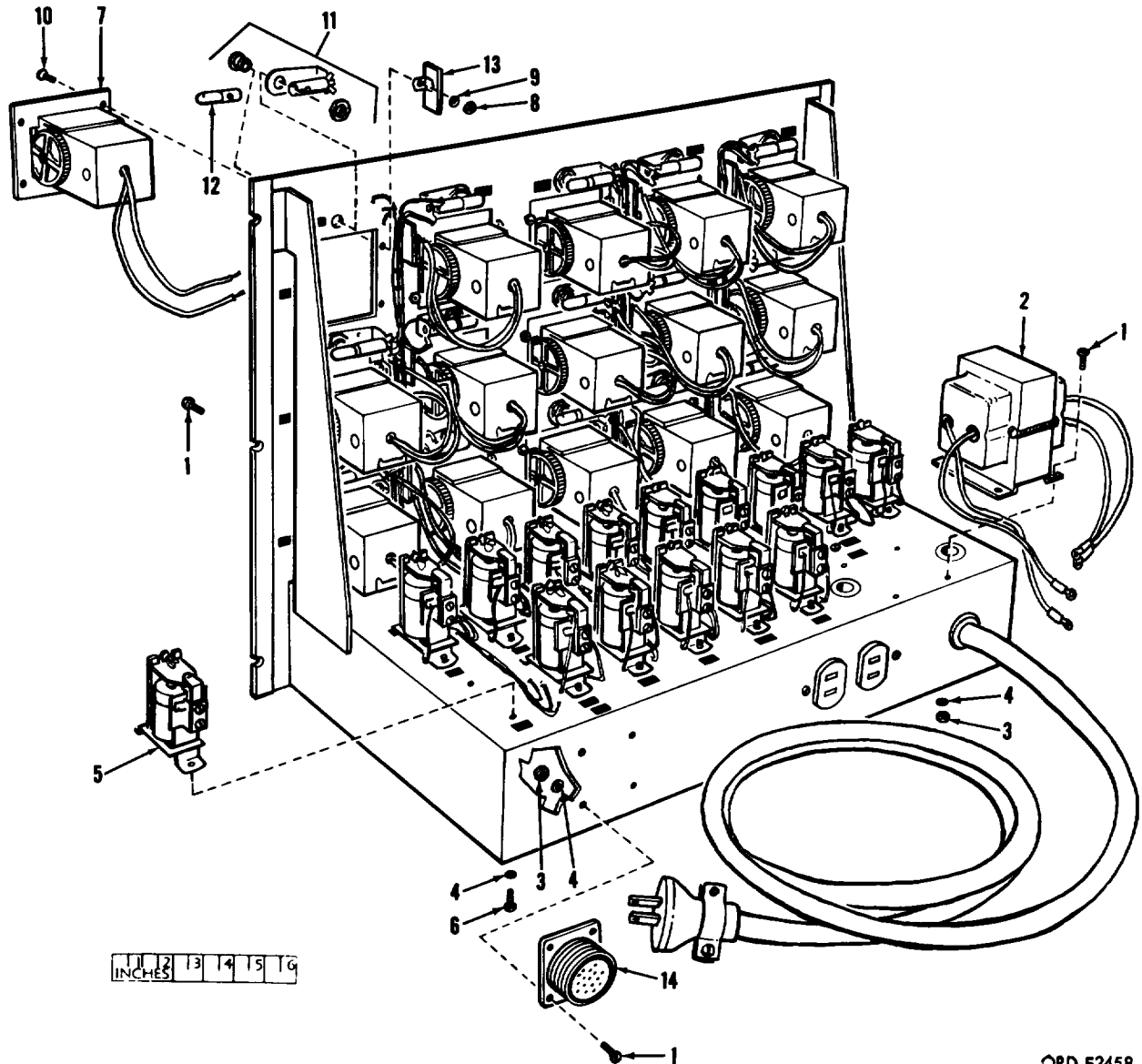

ORD F2458

Figure 23. Counter chassis assembly - partial explode

- | | |
|---|--|
| 1-Machine screw 5305-579-1273 | 8-Hexagon plain nut 5310-271-4642 |
| 2-Step-down power transformer 5950-752-4212 | 9-Lockwasher 5310-058-2949 |
| 3-Hexagon plain nut 5310-271-4644 | 10-Machine screw 5305-022-7056 |
| 4-Lockwasher 5310-209-0766 | 11-Indicator light 6210-299-5153 |
| 5-Target night firing relay 5945-671-4087 | 12-Incandescent lamp 6240-155-8706 |
| 6-Machine screw 5305-579-3019 | 13-Terminal board 5940-177-9863 |
| 7-Electrical counter 6680-542-1782 | 14-Electrical receptacle connector 5935-280-2077 |

Figure 22. Counter chassis assembly - partial exploded top view.

- (5) Visually inspect for any obvious defects such as damage to the case terminal post threads or the breaking away of the terminal post.
- (6) Visually inspect light assemblies for cracked or broken lenses, stripped or

crossed bushing, and mounting hole threads, dents or cracks in the case and the presence of a lamp in the socket. Check to see if correct lamps are installed, securely seated, and not damaged or burned out.

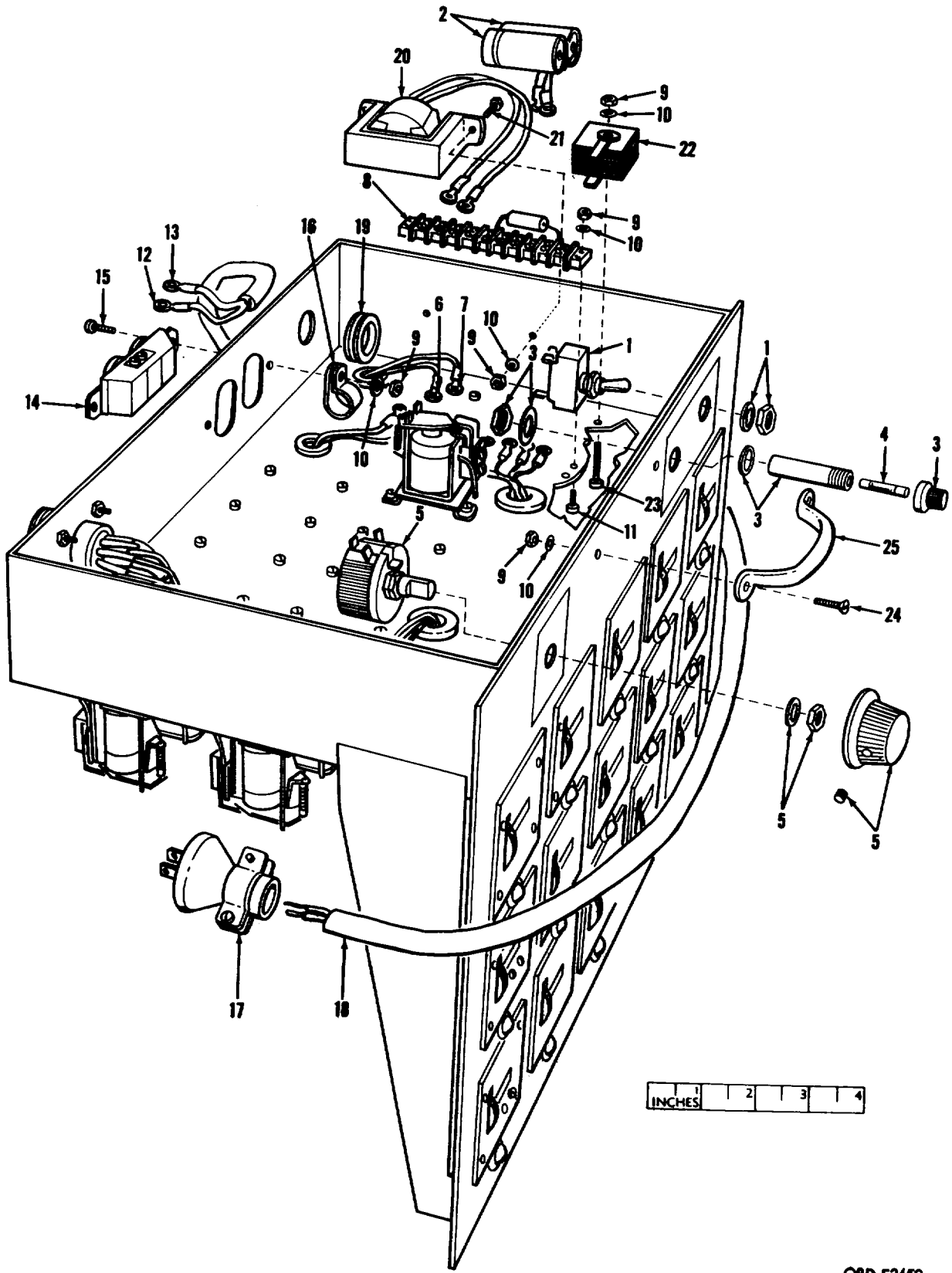

Figure 23. Counter chassis assembly - partial exploded bottom view.

ORD F2459

1-Toggle switch 5930-050-2708
 2-Electrolytic fixed capacitor 5910-644-0746
 3-Fuseholder 5920-526-0538
 4-Cartridge fuse 5920-010-6652
 5-Variable resistor 5905-114-8788
 6-Lug terminal 5940-204-7830
 7-Lug terminal 5940-503-9995
 8Terminal board 5940-375-5554
 9-Hexagon plain nut 5310-271-4644
 10-Lockwasher 5310-209-0766
 11-Machine screw 5305-579-0969
 12-Lug terminal 5940-577-3712
 13-Lug terminal 5940-501-7582

14-Electrical receptacle connector 5935-257-9337
 15-Machine screw 5305-579-3019
 16-Cable clip 7546011
 17-Electrical plug connector 5935-259-1818
 18-Electrical power cable 6145-834-6953
 19-Rubber grommet 5325-263-6632
 20-Step-down power transformer 5920-645-8231
 21-Machine screw 5305-579-1273
 22-Metallic rectifier 6130-671-4073
 23-Machine screw 5305-579-0976
 24-Machine screw 5305-022-7101
 25-Door pull 7545950

Figure 23 - Continued

- (7) Replace any authorized part which is found to be defective through inspection in (1) through (6) above.
- (8) Visually inspect chassis for dirt, rust, corrosion, and fungus growth. Clean as necessary.
- (9) Check fuse for correct type and ampere rating. Replace if necessary.

d. Assembly.

Note. For all necessary wiring details during assembly instructions contained in (1) through (17) below, refer to wiring diagram shown in figure 24.

- (1) Attach door pull (25, fig. 23) to counter chassis assembly with two machine screws (24, fig. 23), two lockwashers (10, fig. 23), and two plain nuts (9, fig. 23).
- (2) Attach the metallic rectifier (22, fig.23) to bottom of chassis with machine screw (23, fig. 23), lockwasher (10, fig. 23), and plain nut (9, fig. 23). Solder wires to leads.
- (3) Align mounting holes of step-down transformer (20, fig. 23) with two holes in chassis and secure with two machine screws (21, fig. 23), two lockwashers (10, fig. 23), and two plain nuts (9, fig. 23). Connect leads to transformer.
- (4) Insert end of power cable (18, fig. 23) through hole in rubber grommet (19, fig. 23) and slide grommet into place in rear of chassis. Connect wire of cable to plug connector (17, fig. 23) and tighten clamp around plug connector.
- (5) Slip cable clip (16, fig. 23) around electrical cable assembly. Aline mounting holes in rear of chassis with holes in receptacle connector (14, fig. 23) and cable clip and secure two machine screws

- (15, fig. 23), two lockwashers (10, fig. 23), and two plain nuts (9, fig. 23). Connect lug terminals (12 and 13, fig. 23) to terminals of the receptacle connector.
- (6) Position terminal board (8, fig. 23) to bottom of chassis and secure with four machine screws (11, fig. 23), four lockwashers (10, fig. 23), and four plain nuts (9, fig. 23). Connect lug terminals (6 and 7, fig. 23) to terminals.
- (7) Insert shaft end of variable resistor (5, fig. 23) through mounting hole in lower right corner of the chassis and secure with resistor mounting nut Make sure resistor has been turned counterclockwise its full limit of travel (OFF position). Insert knob onto shaft and position arrow on knob adjacent to the OFF position on the intensity decal. Tighten setscrew in knob of resistor to secure knob on shaft of resistor.
- (8) Install cartridge fuse (4, fig. 23) in fuse holder and screw cap onto fuse holder by turning clockwise.
- (9) Insert fuse holder (3, fig. 23) into hole in lower left section of the chassis and secure with mounting nut Solder wires to terminals of the fuse holder.
- (10) Solder terminal leads to the fixed capacitors (2, fig. 23) and connect leads to the terminal board.
- (11) Insert toggle end of power toggle switch (1, fig. 23) through mounting hole in lower left corner of chassis and position switch so that toggle is in up position when switch is closed (ON

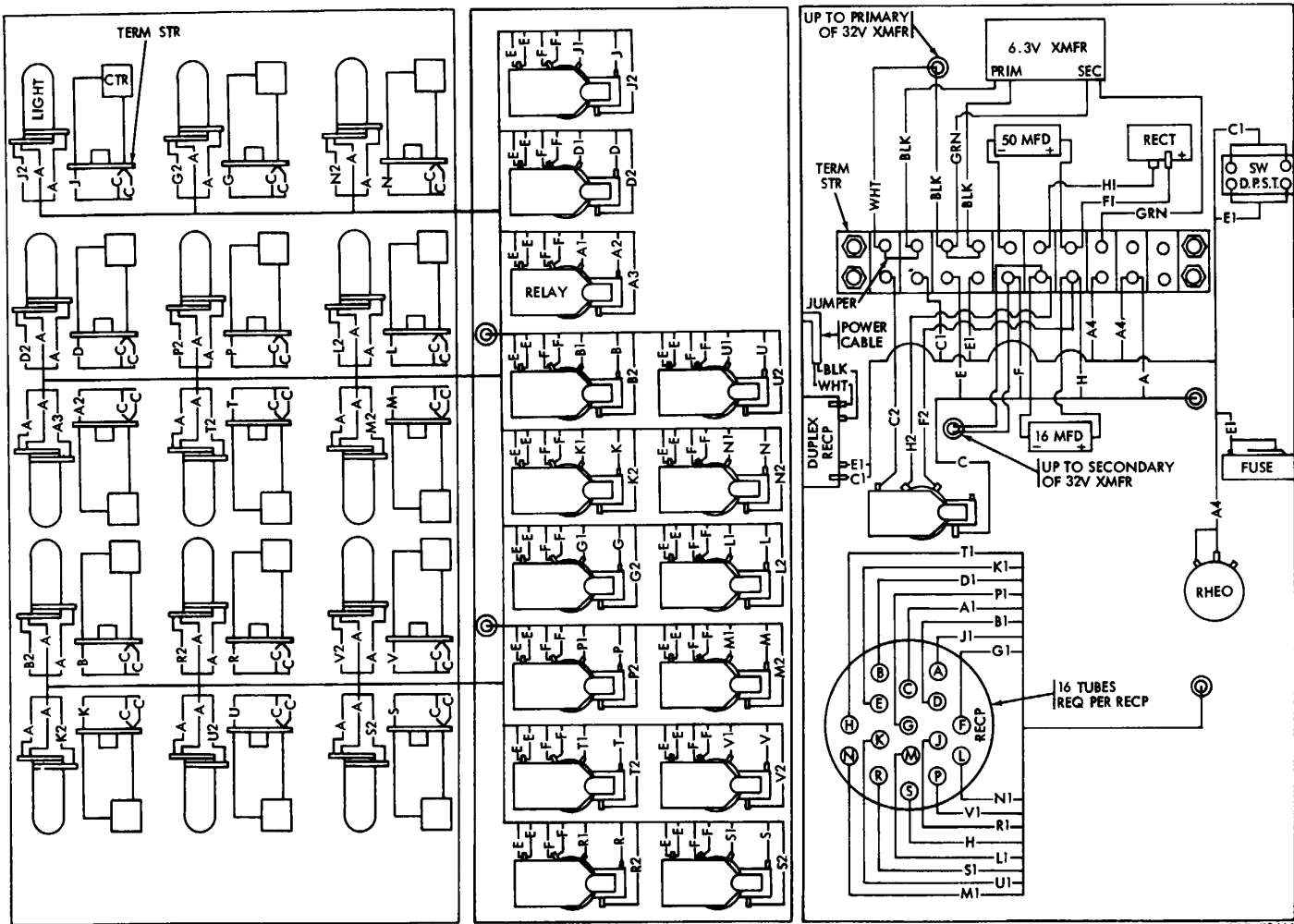

ORD F2460

Figure 24. Counter chassis assembly - wiring diagram

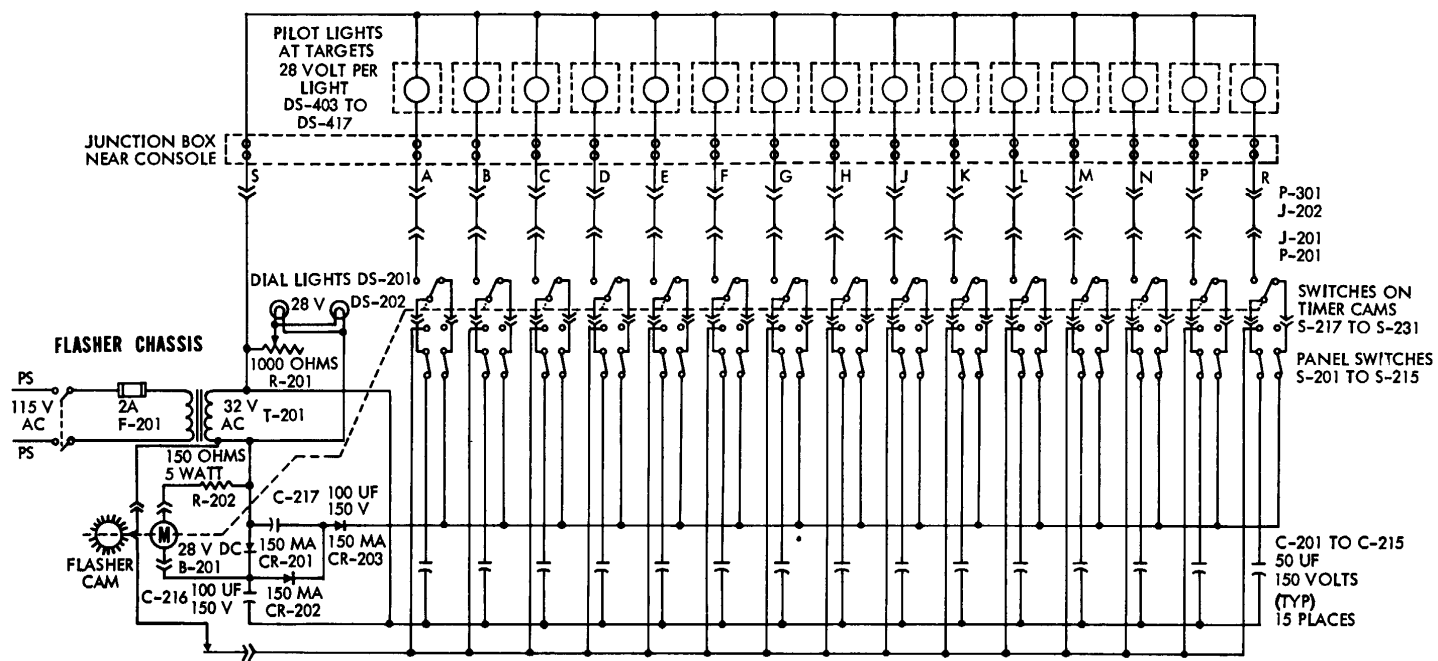

Figure 25. Flasher chassis assembly schematic diagram

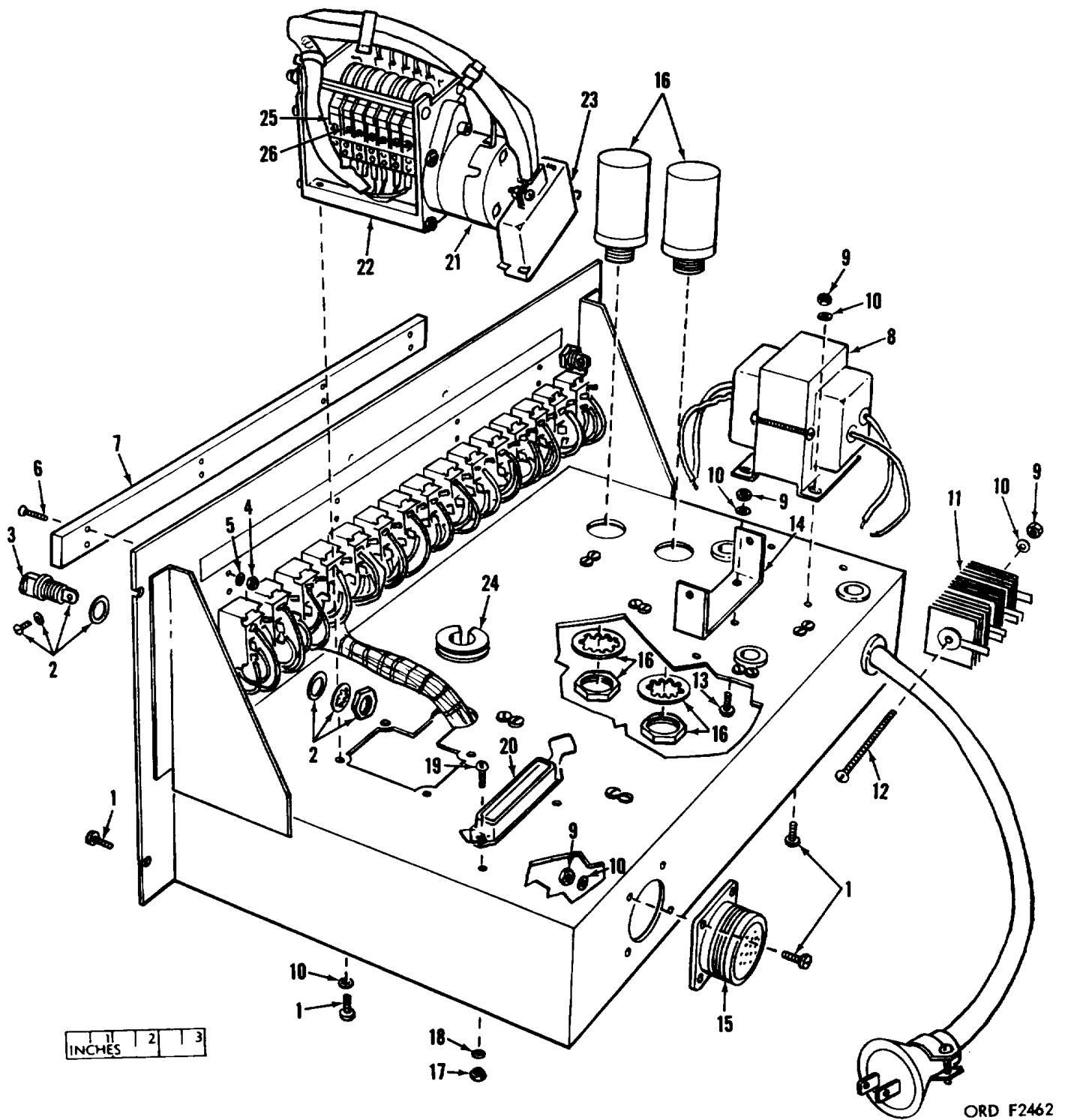

Figure 26. Flasher chassis assembly - partial exploded top view.

1-Machine screw 5305-579-1273
2-Panel light 6210-678-1731
3-Incandescent lamp 6240-155-7836
4-Hexagon plain nut 5310-271-4642
5-Lockwasher 5310-0582949
6-Machine screw 5305-515-7219
7-Illuminated switch strip 7545966
8-Step-down power transformer 5950-752-4212
9-Hexagon plain nut 5310-271-4644
10-Lockwasher 5310-2090766
11-Metallic rectifier 6130-671-4073
12-Machine screw 5305-543-2761
13-Machine screw 5305-579-3019

14-Rectifier mounting bracket 7545960
15-Electrical receptacle connector 5935280-2077
16-Electrolytic capacitor 5910-6902731
17-Hexagon plain nut 5310-054-4272
18-Lockwasher 5310-0582950
19-Machine screw 5305543-2759
20-Timer receptacle connector 7546171
21-Precision timing motor 6105-710-5554
22-Repeat cycle timer 6920-862-6945
23-Plug 7546032
24-Rubber grommet 5325-276-6091
25-Electrical special purpose switch 5930-770-9179
26-Switch assembly 5930-690-6566

Figure 26 - Continued position). Secure switch with mounting nut.

(12) Solder wires to pins of receptacle connector (14, fig. 22) and secure to lower rear of chassis with four machine screws (1, fig. 22), four lockwashers (4, fig. 22), and four plain nuts (3, fig. 22).

(13) Insert threaded area on base of indicator light (11, fig. 22) into hole above counter assembly and secure with jewel mounting nut. Secure terminal board (13, fig. 22) to mounting screw of counter ((14) below). Solder wires to terminal of light and terminal board. Insert incandescent lamp (12, fig. 22) in lamp socket, push in, and turn clockwise to install.

(14) Insert electrical counter (7, fig. 22) into front of panel and secure with four machine screws (10, fig. 22), four lockwashers (9, fig. 22), and four plain nuts (8, fig. 22). Solder wire leads to the counters.

(15) Position relay (5, fig. 22) to upper surface of bottom panel of the chassis and secure with two machine screws (6, fig. 22), and two lockwashers (4, fig. 22). Solder wire leads to relay.

(16) Position the step-down transformer (2, fig. 22) to left rear corner of the upper surface of the bottom panel of chassis and secure with four machine screws (1, fig. 22), four lockwashers (4, fig. 22), and four plain nuts (3, fig. 22). Solder wire to leads of transformer.

(17) With the aid of the handle on the front of the chassis, insert chassis into upper front area of the cabinet, and slide it into the cabinet. Aline the three holes on each side of front panel with holes in

cabinet and install the six machine screws (1, fig. 22) to secure chassis in cabinet.

43. Flasher Chassis Assembly

a. General. The flasher chassis assembly consists of the repeat cycle timer for the indicator lights on the target and panel of the counter chassis; 15 toggle switches for control of the indicator lights and one toggle switch to control the power source; a step down transformer and a bank of three rectifiers to furnish 28 volts of direct current; two panel lights and their resistor for controlling the intensity of illumination; power cable and terminal box cable receptacle connector; and additional electrical components and attaching hardware. Refer to figure 25 for a schematic diagram of the flasher chassis assembly.

b. Disassembly.

Note. The key numbers shown below in parentheses refer to figures 26 and 27.

- (1) From both sides of front panel of flasher chassis assembly, remove four machine screws (1, fig. 26) securing chassis in cabinet assembly. Using the door pull on the chassis, pull out and remove flasher chassis assembly.
- (2) Disconnect leads to panel light (2, fig. 26) and unscrew knurled cap of light, turning it counterclockwise. Remove the incandescent lamp (3, fig. 26). Unscrew the mounting nut of the panel light and remove light from the panel.
- (3) Unscrew and remove eight plain nuts (4, fig. 26), eight lockwashers (5, fig. 26), and eight machine screws (6, fig. 26) securing illuminated switch strip

- (7, fig. 26) to the front panel of the chassis.
- (4) Disconnect leads from step-down transformer (8, fig. 26) and remove four plain nuts (9, fig. 26), four lockwashers (10, fig. 26), and four machine screws (1, fig. 26).
 - (5) Unsolder connections on the three metallic rectifiers (11, fig. 26). Remove the rectifiers from the rectifier mounting bracket by unscrewing and removing plain nut (9, fig. 26), lockwasher (10, fig. 26), and machine screw (12, fig. 26). Remove the two plain nuts (9, fig. 26), two lockwashers (10, fig. 26), and two machine screws (13, fig. 26) securing rectifier mounting bracket to flasher chassis. Remove rectifier mounting bracket (14, fig. 26).
 - (6) Unsolder wires from pins of receptacle connector (15, fig. 26), and remove four plain nuts (9, fig. 26), four lockwashers (10, fig. 26), and four machine screws (1, fig. 26). Remove connector from rear of chassis.
 - (7) Unsolder wire leads on electrolytic capacitors (16, fig. 26) and remove them by unscrewing mounting nuts.
 - (8) Release the two spring wire dips on each side of the plug at rear of precision timing motor (21, fig. 26) and pull plug (23, fig. 26) from receptacle connector. Remove four machine screws (1, fig. 26) and four lockwashers (10, fig. 26) securing repeat cycle timer (22, fig. 26) to flasher chassis assembly. Remove timer. Remove two screws securing cap to rear of motor and disconnect the two leads to the motor. From the left side of the motor remove mounting nut, screw, and washer. Remove the nut and washer from the threaded stud on right side of motor. Pull rearward on motor until stud is free of motor. Revolve motor counterclockwise and work the gear out through opening in timer housing.
 - (9) Revolve the split rubber grommet (24, fig. 26) on timer wiring harness until it can be removed from port cut in the chassis.
 - (10) Remove two plain nuts (17, fig. 26), two lockwashers (18, fig. 26), and two machine screws (19, fig. 26) from timer receptacle connector. Remove receptacle connector (20, fig. 26).
 - (11) Unsolder leads at terminals of variable resistor (1, fig. 27) and loosen setscrew in control knob (2, fig. 27) of resistor. Pull knob off shaft of resistor and unscrew the mounting nut securing resistor to panel. Remove resistor.
 - (12) Unsolder wires at terminals of fuse holder (3, fig. 27) and unscrew mounting nut from front of fuse holder. Separate fuse holder from front panel. Unscrew cap of fuse holder counterclockwise and remove cartridge fuse (4, fig. 27).
 - (13) Unsolder connections on power and target selector toggle switches (5 and 6, fig. 27) and remove the switch from the panel by unscrewing the mounting nut.
 - (14) Disconnect lug terminals (7, fig. 27) of power cable (8, fig. 27) from terminals on power toggle switch. Pull power cable out of rubber grommet (9, fig. 27) and remove grommet from chassis. Unsolder lug terminals and remove from ends of power cable. Remove clamp from electrical plug connector of power cable and disconnect wire from terminals of plug connector. Remove electrical plug connector (10, fig. 27) from power cable.
 - (15) Disconnect terminals of fixed electrolytic capacitors (11, fig. 27) from terminal boards. Remove capacitors.
 - (16) Disconnect leads from terminal boards (12, fig. 27) and remove from each board four plain nuts (13, fig. 27), four lockwashers (14, fig. 27), and four machine screws (15, fig. 27). Remove terminal boards.
 - (17) Remove two plain nuts (13, fig. 27), two lockwashers (14, fig. 27), and two machine screws (16, fig. 27) from the door pull (17, fig. 27). Remove door pull.

c. Inspection

- (1) Inspect to see that chassis is clean, free from rust, corrosion, and fungus growth. Clean as necessary.
- (2) Inspect lettering on panels, plates, etc. Make sure it is legible and completely filled.
- (3) Inspect cables and wires. See that mounting clamps are in place, secure, and hold cables or wires firmly without pinching. Make sure wires are securely

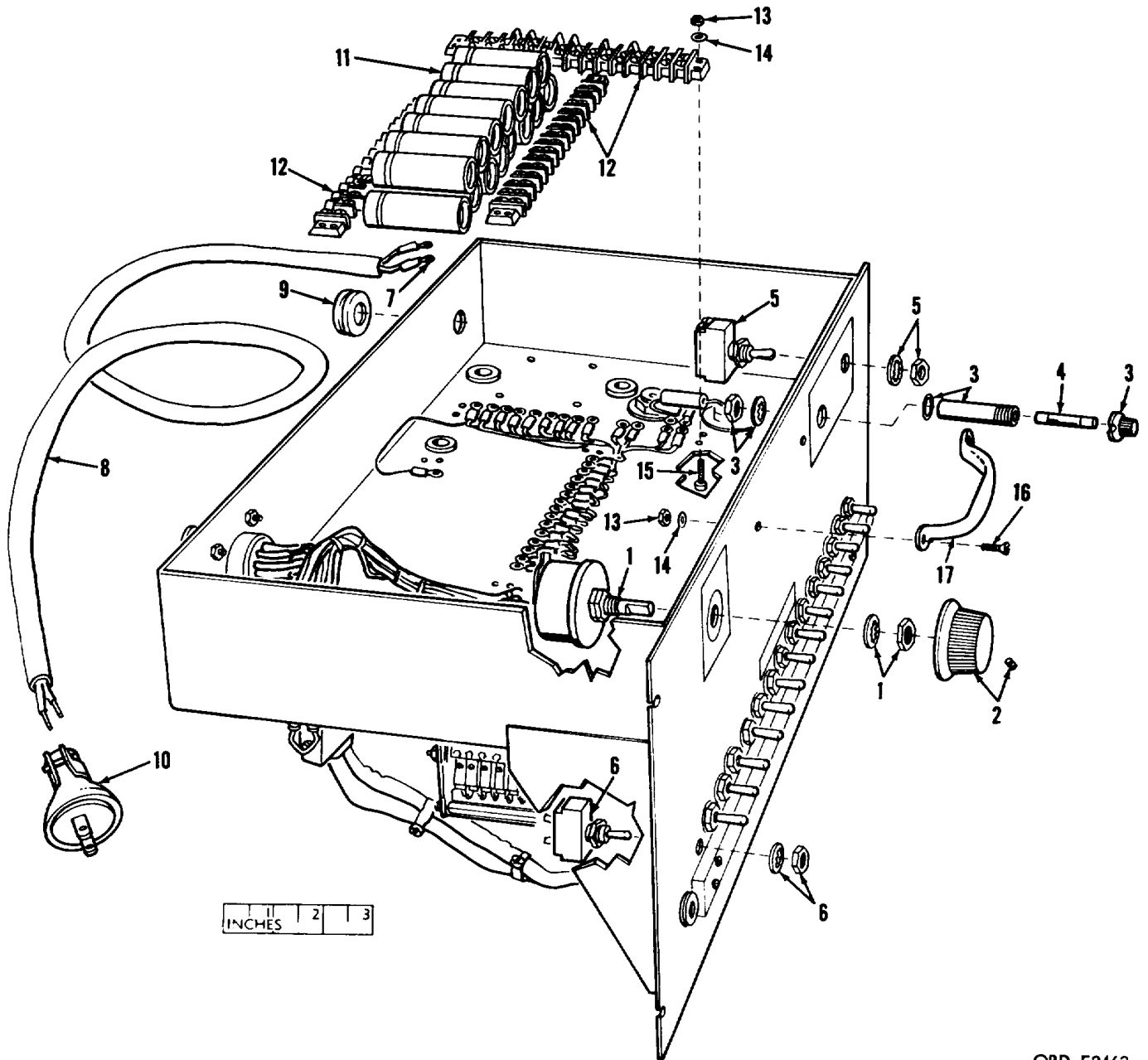

ORD F2463

- 1-Variable resistor 5905-114-9970
- 2-Control knob 5355-619-3835
- 3-Fuseholder 5920-526-0538
- 4-Cartridge fuse 5920-010-6652
- 5-Toggle switch 5930-050-2708
- 6-Toggle switch 5930-050-2704
- 7-Lug terminal 5940-534-0970
- 8-Electrical power cable 6145-834-6953
- 9-Rubber grommet 5325-263-6632

- 10-Electrical plug connector 5935-259-1818
- 11-Electrolytic fixed capacitor 5910-858-6329
- 12-Terminal board 5940-109-2583
- 13-Hexagon plain nut 5310-271-4644
- 14-Lockwasher 5310-209-0766
- 15-Machine screw 5305-579-1273
- 16-Machine screw 5305-022-7101
- 17-Door pull 7545950

Figure 27. Flasher chassis assembly-partial exploded bottom view.

attached to pins and terminals. Insulation should be free from breaks, cracks, tears, cuts, abrasion, oil, grease, and paint

- (4) Inspect plug and receptacle connectors. See that pins are not broken, bent, sprung, burned, or corroded. Make sure threads are not stripped or burred

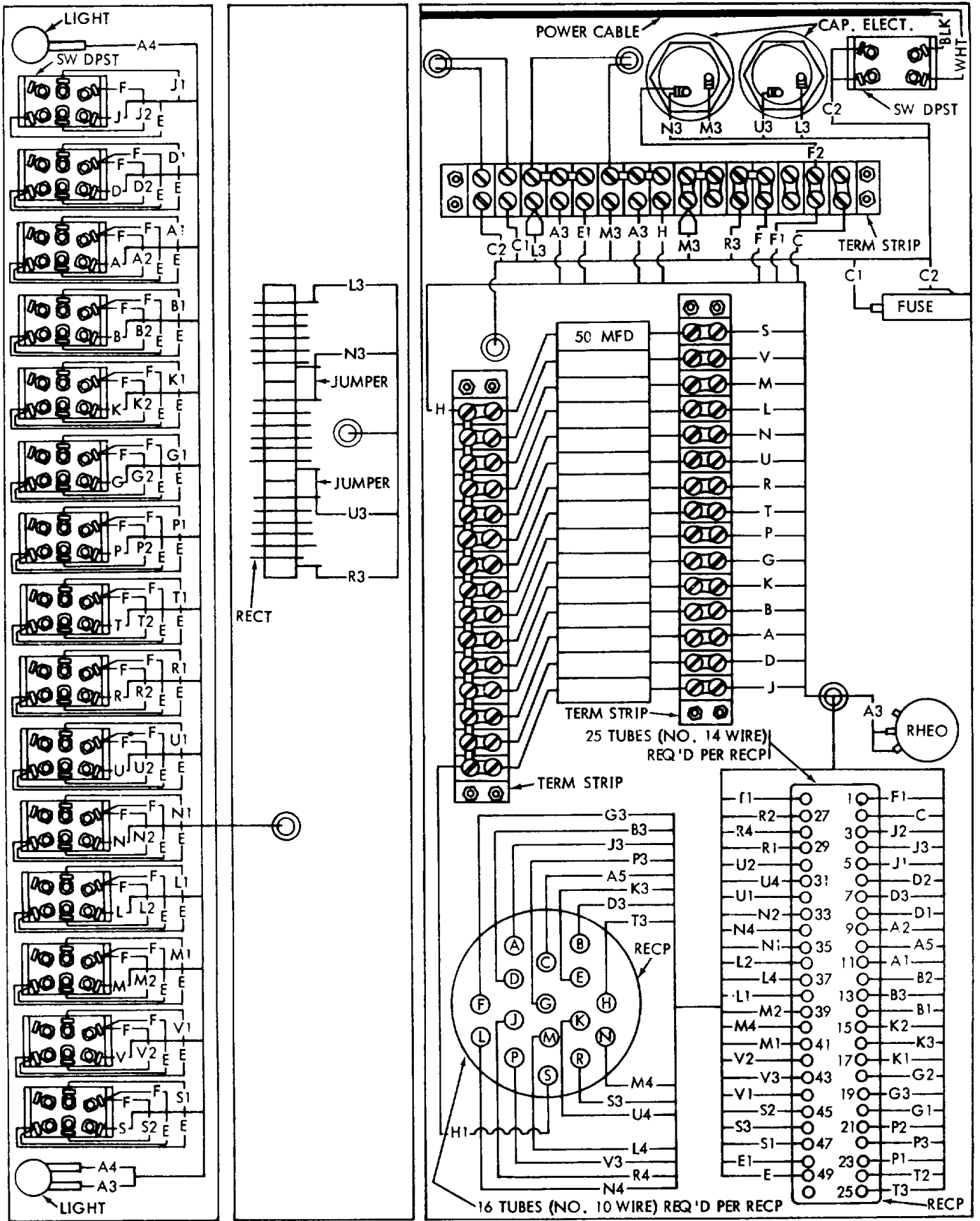

ORD F2464

Figure 28 Flasher chassis assembly - wiring diagram

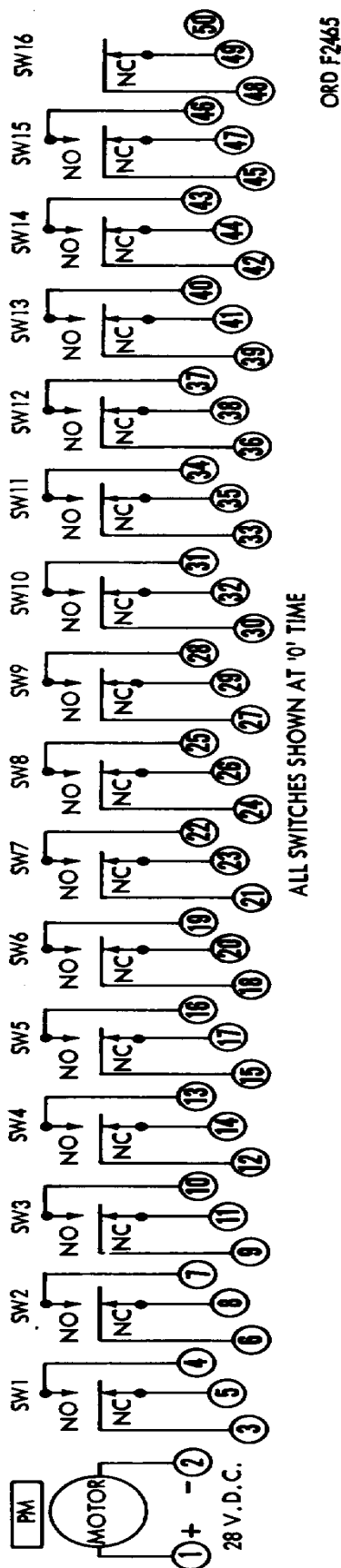

Figure 29. Repeat cycle timer - wiring diagram.

and plug connectors securely mate with correct receptacle connectors.

- (5) Inspect the fuse holder to determine if fuse is installed and not blown, also determine that correct type and ampere rating is installed.
- (6) Inspect panel lights for correct lamp.
- (7) Check toggle switches to see if they move easily to all positions.
- (8) Check capacitors to see if they are securely installed. Make sure they are not cracked, charred, blistered, discolored, or swelled.
- (9) Check to determine if transformer is securely installed. Make sure the potting compound is not leaking.

d. Assembly.

Note. Refer to figures 28 and 29 for necessary wiring diagrams when performing assembly instructions outlined in (9) through (16) below.

- (1) Install two machine screws (16, fig. 27), two lockwashers (14, fig. 27), and two plain nuts (13, fig. 27) to secure door pull (17, fig. 27) to front panel of chassis.
- (2) Position terminal boards (12, fig. 27) to bottom of chassis and secure each board with four machine screws (15, fig. 27), four lockwashers (14, fig. 27), and four plain nuts (13, fig. 27). Connect wire leads to terminal boards.
- (3) Connect terminals of fixed electrolytic capacitors (11, fig. 27) to the two terminal boards (12, fig. 27) running parallel to each other.
- (4) Solder lug terminals (7, fig. 27) to ends of power cable (8, fig. 27). Insert lugs through hole in rubber grommet (9, fig. 27) and install grommet in chassis. Connect lug terminals of power cable to power switch terminals. Connect wires of power cable to terminals in plug connector (10, fig. 27) and attach clamp to plug connector.
- (5) Install the target selector toggle switches (6, fig. 27) in mounting holes running across the upper portion of the front panel. Position each switch so that toggle will be up when switch is placed in the single fire position and securely tighten the mounting nut. Solder lead wires to the terminals of the switches.
- (6) Install power toggle switch (5, fig. 27) in lower left corner of front panel. Position switch so that toggle will be up

when in the ON position, and securely tighten mounting nut. Solder lead wires to connection on the toggle switch.

- (7) Install cartridge fuse (4, fig. 27) in fuse holder and secure cap on fuse holder by turning clockwise. Install fuse holder (3, fig. 27) in mounting hole to right of power switch toggle and secure with mounting nut. Solder wires to terminals of fuse holder.
- (8) Install variable resistor (1, fig. 27) to lower right corner of the front panel and secure with mounting nut. With resistor in the OFF position, adjust control knob (2, fig. 27) so that arrow head is adjacent to OFF on decal and tighten setscrew in knob.
- (9) Install four machine screws (10, fig. 26), four lockwashers (18, fig. 26), and four plain nuts (17, fig. 26) to secure timer receptacle connector (20, fig. 26) to chassis.
- (10) Install split rubber grommet (24, fig. 26) onto wiring harness of timer and work the grommet into the port cut in bottom of chassis.
- (11) Position precision timing motor (21, fig. 26) with gear toward housing. Insert mounting lug on right side of motor onto threaded lug on rear of timer housing.

Caution: Do not use excessive force in trying to engage gear on motor shaft with mating gear on timer cam.

Align gear on motor shaft with hole in timer housing and insert gear into hole. Turn motor clockwise and gently work motor back and forth until gear on motor engages with cam gear. Secure with mounting nuts, washers, and screw. Connect leads to motor and install cap to rear of motor with two screws and two washers. Install repeat cycle timer (22, fig. 26) and secure with four machine screws (1, fig. 26) and four lockwashers (10, fig. 26). Install plug (23, fig. 26) into receptacle connector and secure by engaging wire clips at each side of the plug.

(12) Insert bases of electrolytic capacitors (16, fig. 26) through holes near left side of upper surface of chassis and secure with mounting nuts on bottom surface of chassis. Solder wire leads to capacitors.

(13) Install receptacle connector (15, fig. 26) to right lower rear corner of chassis and secure with four machine screws (1, fig. 26), four lockwashers (10, fig. 26), and four plain nuts (9, fig. 26). Solder wires to pins of connectors.

(14) Install rectifier mounting bracket (14, fig. 26) to rear top surface of bottom panel with two machine screws (13, fig. 26), two lockwashers (10, fig. 26), and two plain nuts (9, fig. 26). Position the three metallic rectifiers (11, fig. 26) between the upright arms of the bracket and insert machine screw (12, fig. 26) through bracket and rectifiers and secure with lockwasher (10, fig. 26), and plain nut (9, fig. 26). Solder wires to connections of rectifiers.

(15) Position and align holes in step-down transformer (8, fig. 26) with holes in left corner of top surface of the bottom panel and secure with four machine screws (1, fig. 26), four lockwashers (10, fig. 26), and four plain nuts (9, fig. 26). Connect leads of transformer.

(16) Install eight machine screws (6, fig. 26), eight lock washers (5, fig. 26), and eight plain nuts (4, fig. 26) to secure the illuminated switch strip (7, fig. 26) to front panel.

(17) Install panel lights (2, fig. 26) attach end of the illuminated switch strip so that opening in light will face the end of the strip, and secure with mounting nut. Insert incandescent lamp (3, fig. 26) into cap of light and screw cap into panel light. Connect wires to terminals of light.

(18) Using the door pull on front of flasher chassis assembly, insert the chassis in the lower part of cabinet assembly and secure with four machine screws (1, fig. 26).

**Section IV. REPAIR OF TERMINAL BOX ASSEMBLY, TARGET
HOLDER ASSEMBLY, HIT SWITCH ASSEMBLIES,
AND UTILITY BOX ASSEMBLIES**

44. General

This section contains the procedures for field maintenance of the terminal box assembly, target holder assembly, hit switch assemblies, and utility box assemblies. The repair procedures for each of these are covered in separate paragraphs within this section.

45. Terminal Box Assembly

a. General The terminal box assembly provides the junction for all field wires to the targets. The terminal box is a steel rectangular shaped box with a hinged lid. Four terminal boards are mounted to the bottom of the box. Two cable assemblies permit it to be plugged into the counter chassis and to the flasher chassis. Knockouts around the lower portion of the sides and ends of the box are provided for accepting the field wires from each target. Notes The key numbers shown below in parentheses refer to figure 30.

b. Disassembly. Disconnect lug terminals (1) from terminal boards (2). Unscrew coupling nuts (3) and pull cable assemblies (4) from terminal box. Loosen clamps on plug connectors (5) and disassemble plug connectors. Unsolder wire of cable from pins in plug connectors and from lug terminals on opposite ends of cable assemblies. Remove terminal boards from bottom of box by removing plain nuts (6), lockwashers (7), and machine screws (8).

c. Inspection.

- (1) Inspect the terminal box for cracks and broken welds.
- (2) Visually inspect all wiring for evidence of shorts, insulation breakdown, or abrading away of protective covering.
- (3) Inspect connector threads for striping, marring, or crossed threads.
- (4) Check color code paint on ends of plug connectors. End of plug connected to the terminal board of the hit switches should be color coded red. The end of the other connector should be green. If paint is illegible, faded, or worn off paint as required.
- (5) Replace authorized repair parts, if defective, as outlined in d(1) through (4) below.

d. Assembly.

- (1) Install terminal boards (2) to bottom of terminal box by securing with machine screws (8), lockwashers (7), and plain nuts (6).
- (2) Solder wire of cable assemblies (4) to lug terminals (1) and to pins of plug connectors (5).
- (3) Assemble plug connector and securely tighten clamp to cable.
- (4) Insert ends with lug terminals through conduit opening and connect terminals to boards. Tighten coupling nuts (3). Connect jumpers to terminal boards.

46. Target Holder Assembly

a. General The target holder assembly is an arch-shaped aluminum clamp for holding the silhouette target.

b. Disassembly.

Note. The key numbers shown below in parentheses refer to figure 31.

- (1) Remove back plate (1) and front plate (2) of target holder assembly by removing (fig. 32) three wing nuts (3) three flat washers (4), two square neck bolts (5), and one square neck bolt (6).
- (2) Separate wood block (7) from holder by removing plain nut (8), flat washer (4), and machine screw (9).

C Inspection.

- (1) Inspect front plate of holder assembly to see if rubber pads are serviceable and securely cemented.
- (2) Inspect front and back plates. If cracked, bent, or badly shot up, replace with new target holder assembly.
- (3) Inspect for defective or missing nuts, screws, and washers. Replace hardware as necessary.

d Assembly.

- (1) Align holes in wood block (7) with holes in front plate (2). Insert machine screw (9) through bottom hole in front plate and wood block, secure with flat washer (4) and plain nut (3).
- (2) Mate back plate (1) with front plate. Align holes and install square neck

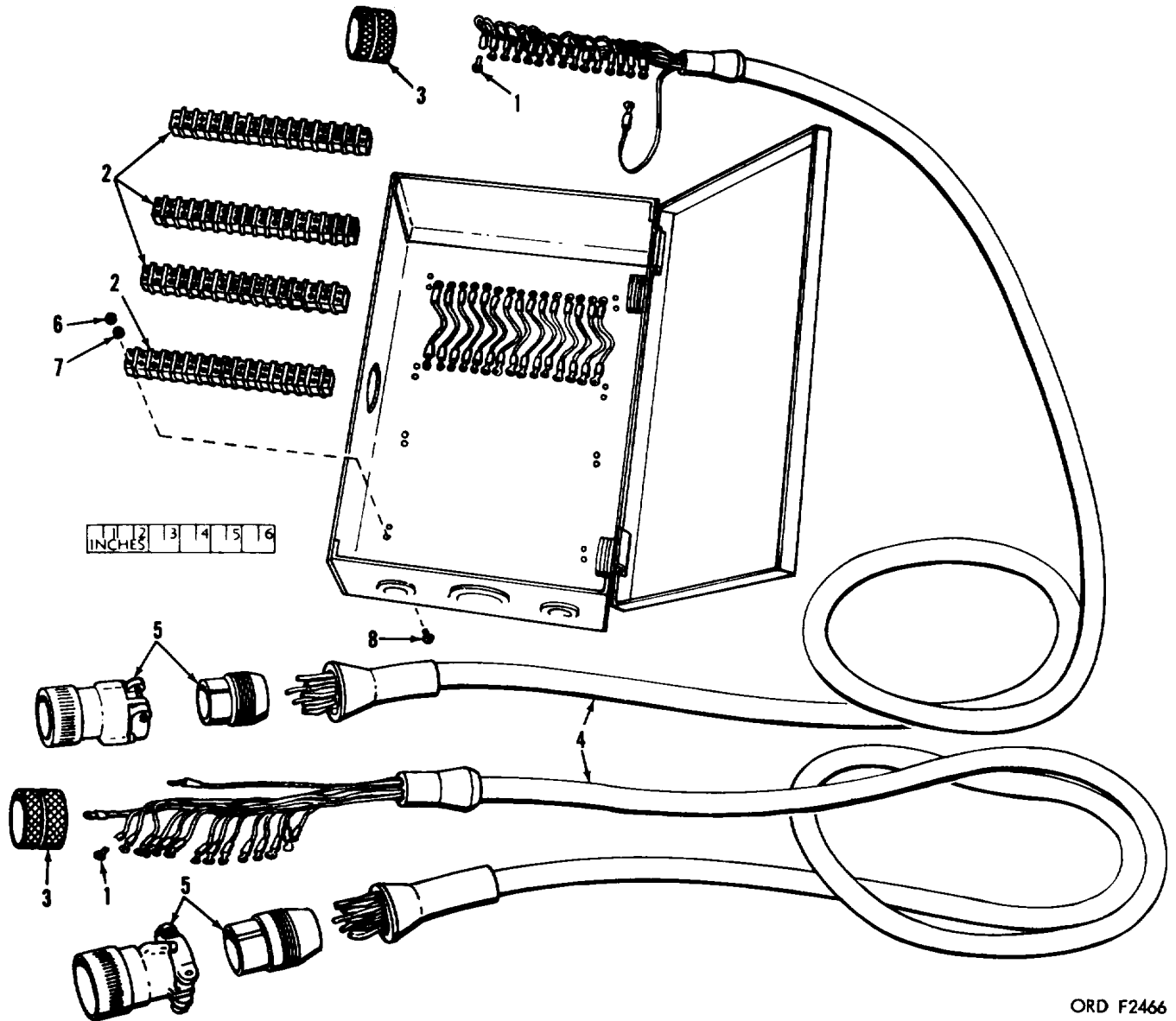

ORD F2466

- 1-Lug terminal 5940-204-7830
- 2-Terminal board 5940-109-2583
- 3-Electrical conduit coupling nut 5975-821-6446
- 4-Electrical special purpose cable assembly 6920-862-4759

- 5-Electrical plug connector 5935-201-6635
- 6-Hexagon plain nut 5310-271-4644
- 7-Lockwasher 5310-209-0766
- 8-Machine screw 5305-6543-5763

Figure 30. Terminal box assembly (6920-861-3835) partial exploded view.

bolt (6) through plates and wood block, square neck bolts (5) in two outer holes, and secure all bolts with three flat washers (4) and three wing nuts (8)

damps which permit the switches to be installed to the target holder assembly.

b. Disassembly.

Note. The key numbers shown below in parentheses refer to figure 33.

47. Hit Switch Assembly

a. General. The hit switch assembly is composed of two cables, two sensitive switches, and a plug connector. The two switch assemblies are provided with

- (1) Remove two machine screws (1), two machine screws (2), two lockwashers (3), and four plain nuts (4) securing

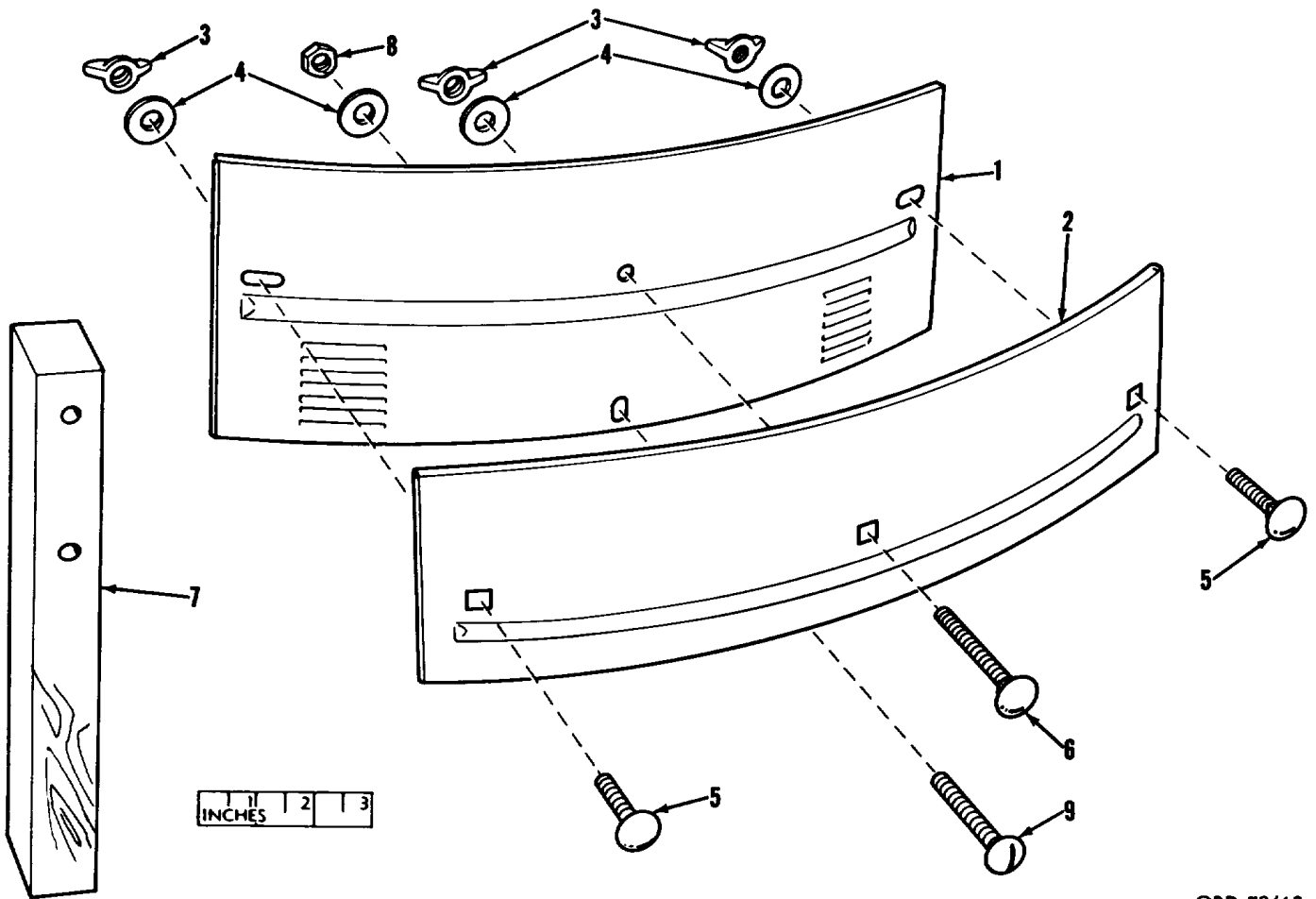

ORD F2468

- 1-Plate 7546063
- 2-Plate 7546064
- 3-Plain wing n& 531451&9271
- 4-Flat washer 5310-54-2870
- 5-Square neck bolt 5306-0126358

- 6-Square neck bolt 5306012-6385
- 7-Wood block 692047S3734
- 8-Hexagon plain nut 5310-543-2629
- 9-Machine screw 5305543-2833

Figure 31. Target holder assembly 692f475-3733) - exploded view.

- the sensitive switches (5) to their Covers.
- (2) Remove switch dampers (6) from sensitive switches.
- (3) Pull cover away from sensitive switches and unsolder cable wires from terminals in sensitive switches. Remove cables (8A and 8B) from sensitive switches.
- (4) Remove covers (7) from sensitive switches.
- (5) Remove damp from plug connector, disconnect cable wires from plug connector terminals, and remove cable (8B) from plug connector (9).

c. *Inspection* Visually inspect switches and their terminals for any defects that could render the switches

inoperable, such as broken cases, or cracks and breaks in the covers. Replace authorized repair parts, if defective, as outlined in d below.

d. *Assembly.*

- (1) Insert cable (8B) in connector plug (9), connect cable wires to plug connector terminals, and secure damp to plug connector.
- (2) Solder cable wires of cables (8A and 8B) to terminals in sensitive switches and install covers (7) on sensitive switches (5).
- (3) Position switch dampers (6) and secure to sensitive switches with four plain nuts (4), two lockwashers (3), two machine screws (2), and two machine screws (1).

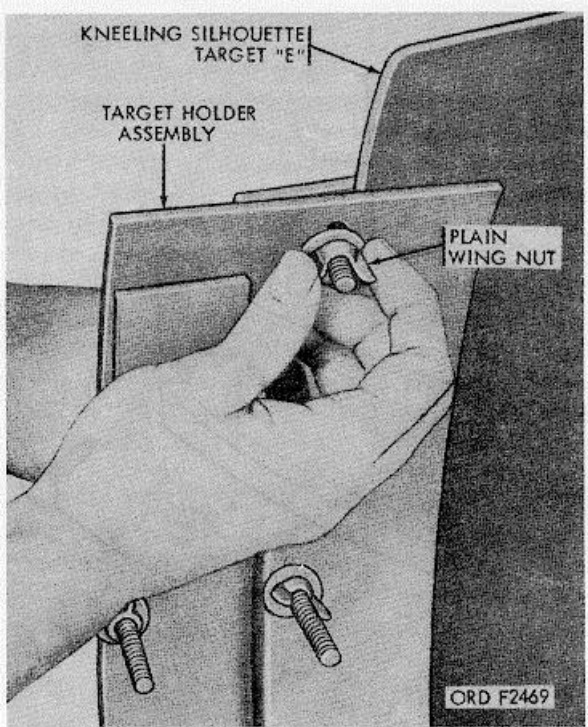
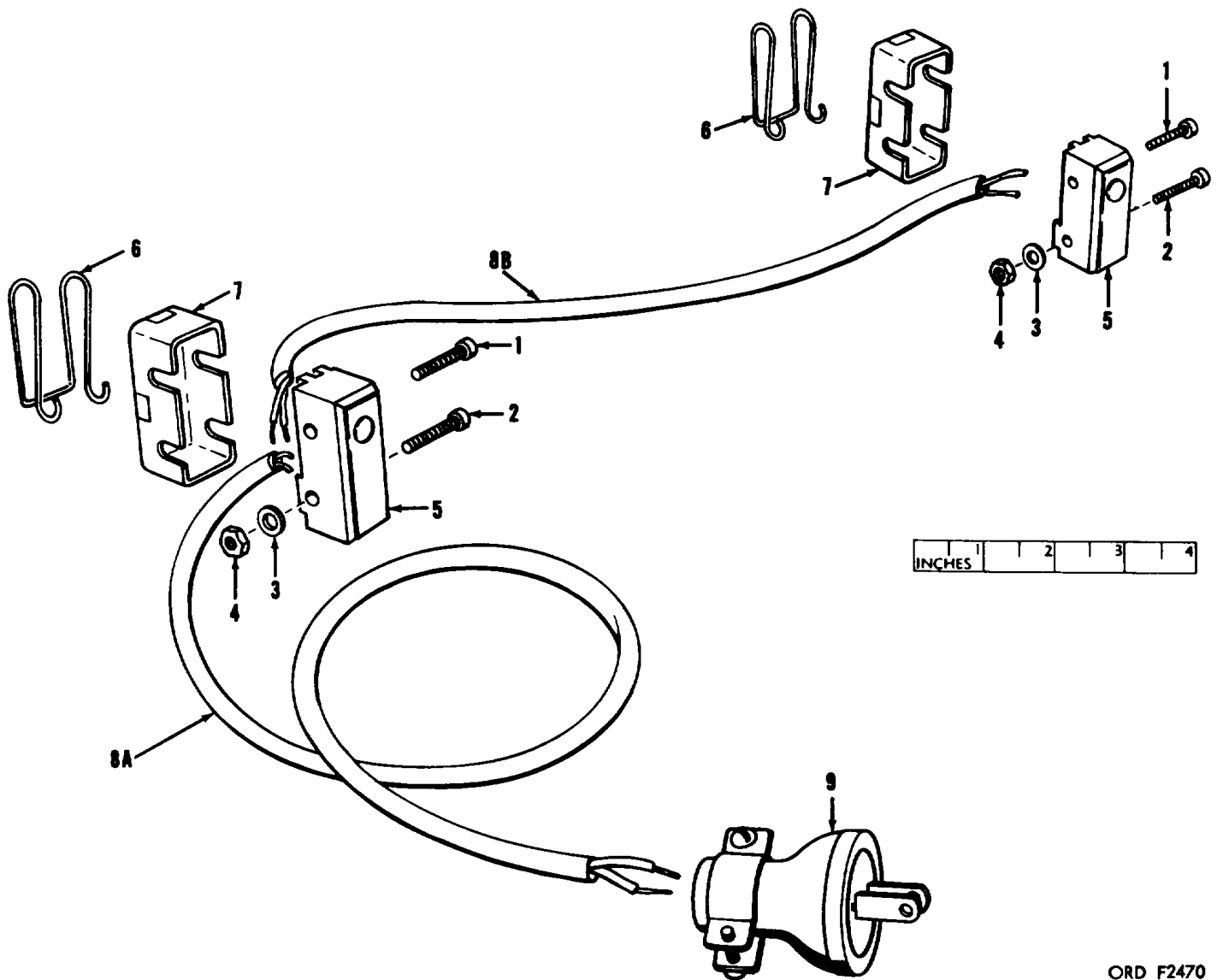

Figure 32. Removing or installing target holder assembly

48. Utility Box Assembly (fig. 34)

The utility box assembly consists of the utility box, utility box cover, and a single receptacle. The utility box assemblies are used as junction points to connect the hit switch assemblies and target indicator lights to the terminal box assembly by means of field wires (fig. 35).



- 1-Machine screw 5305-0586872
- 2-Machine screw 53050586874
- 3-Lockwasher 5310281-1405
- 4-Hexagon plain nut 5310271-4644
- 5-Sensitive switch 5930607-2710

- 6-Switch damp 6920-897-2456
- 7-Switch terminal cover 5973703966
- 8A-Electrical cable 773249A
- 8B-Electrical cable 7732849B
- 9-Electrical plug connector 593259-1818

Figure 33. Hit switch assembly - partial exploded view.

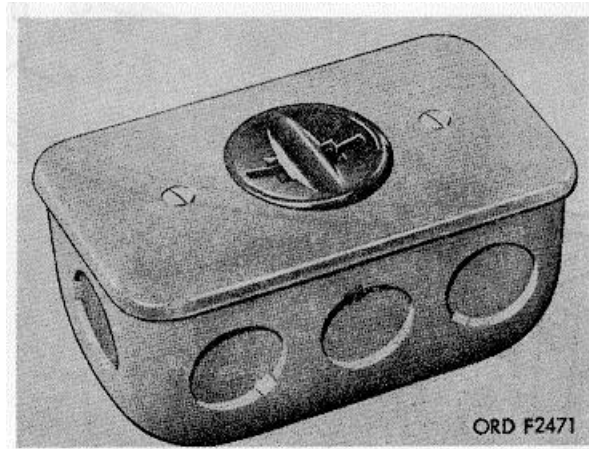

Figure 34. Utility box assembly (6920-861-3836).

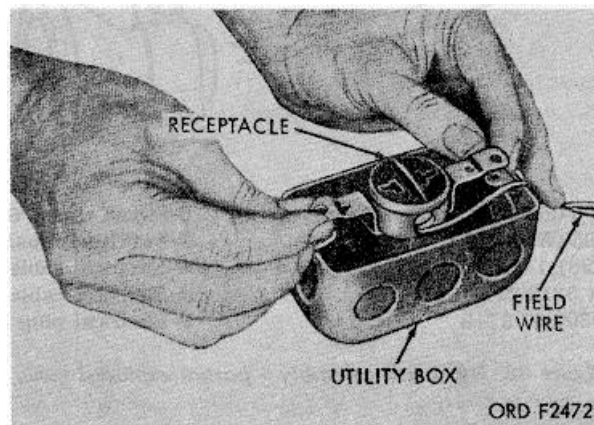

Figure 35. Installing field wires in utility box assembly.

CHAPTER 5

SHIPMENT AND STORAGE

49. Shipping Instructions

a. *Responsibilities.* When shipping the material officer in charge of preparing the shipment will be responsible furnishing the material in a serviceable condition and properly processed for shipment including the preparation of Army shipping documents.

b. *Army Shipping Documents.* Prepare all Army shipping documents in accordance with AR 725-5

c. *Preparation for Shipment* Materiel removed from storage for shipment, need not be reprocessed unless inspection reveals it to be inadequately preserved or when it is necessary because of anticipated in-transit adverse weather or shipping conditions. Preservatives must not be removed or disturbed unless it is necessary to insure that the materiel is complete and serviceable. If preservatives are removed, they must be restored prior to shipment

50. Limited-Storage Instructions

a. *General.*

- (1) Materiel received for storage and already processed for domestic shipment as indicated on the processing record tag (DA Form 914), must not be processed unless the inspection upon receipt of materiel, reveals cosign, deterioration, etc
- (2) Completely process materiel upon receipt directly from manufacturing facilities or if the processing date recorded on the tag indicate that it has been rendered ineffective by operation or freight shipping damage.
- (3) materiel to be prepared for limited storage must be given a limited technical inspection and be processed as prescribed in TB 9-299/ 1.

b. *Receiving Inspections*

- (1) Report of materiel received for storage in a damaged condition or improperly prepared for shipment will be made on DD Form 6, in accordance with AR -700-58.
- (2) When materiel is inactivated, it is to be placed in a limited-storage status for periods not to exceed 90 days Standby storage for periods in excess of 90 days will normally be handled by Ordnance maintenance personnel only.

- (3) Immediately upon receipt of materiel for storage, the weapon must be inspected and serviced as prescribed in paragraphs 26 and 28. Perform a systematic inspection and replace or repair all missing or broken parts. If repairs are beyond the scope of the unit and the materiel will be inactivated for an appreciable length of time, place it in a limited-storage status and each tag specifying the repairs needed. The report of these conditions will be submitted by the unit commander for action by an Ordnance maintenance unit.

c. *Inspection During Storage.* Perform a visual inspection periodically to determine general condition. If corrosion is found on any part remove it and clean and paint or treat with the prescribed preservatives.

Note. Touchup painting will be in accordance with TM 9 2851.

d. *Removal from Limited Storage*

- (1) If the materiel will not be shipped or issued upon expiration of the limited storage period, it may either be processed for another limited-storage period or treated further for stand-by storage period in excess of 90 days and up to 3 years by Ordnance maintenance personnel.
- (2) If the materiel to be shipped will reach its destination within the limited-storage period, it need not be reprocessed upon removal from storage unless inspection reveals it to be necessary according to anticipated in-transit weather conditions.

Note. All materiel being reissued through the depot supply system troops within the continental limits of the United States must meet the requirements of TB ORD 385. This NOT required for so-all reissues, exchanges, or redistribution among troop units, where the depot supply system is not involved.

- (3) Deprocessed materiel when it has been ascertained that it is to be placed in immediate service.

(4) Repair and/or replace all items tagged in accordance with b(3) above.

e. *Storage Site.* The preferred type of storage for this materiel is under cover in open sheds or in warehouses, whenever possible. Where it is found necessary to store materiel outdoors, the storage site must be deleted in accordance with and the materiel protected against the elements as prescribed in TB ORD 379.

51. Packing and Marking Instructions

a. *Packing.* Pack the materiel in PPP-B-621, class stle 4, woode box having inside dimensions of 303/4 x 21-5/8 x 24-3/4. The box will be made of 3/4-inch lumber and constructed in accordance with TM 9-200.

b. *Marking.* Marking instructions will be in accordance with AR 746-80 and TM 9-200

APPENDIX I

REFERENCES

1. Publication Indexes

The following indexes should be consulted frequently for latest changes or revisions of references given in this appendix and for new publications relating to materiel covered in this manual.

Index of Army Motion Pictures, Film Strips, Slides, and Phono-Recordings.	DA Pam 108-1
Military Publications:	
Index of Administrative Publications	DA Pam 310-1
Index of Blank Forms.....	DA Pam 310-2
Index of Graphic Training Aids and Devices	DA Pam 310-5
Index of Supply Manuals; Ordnance Corps	DA Pam 310-29
Index of Tables of Organization and Equipment, Tables of Organization, Type Tables of Distribution, and Tables of Allowances.	DA Pam 310-7
Index of Technical Manuals, Technical Bulletins, Supply Bulletins, Lubrication Orders, and Modification Work Orders.	DA Pam 310-4
Index of Training Publications	DA Pam 310-3

2. Supply Manuals

The following supply manuals of the Department of the Army supply manual pertain to this materiel:

Hardware and Abrasives (Class 5340 Miscellaneous Hardware).....	SM 9-1-5340
Shop Set, Small Arms: Field Maintenance	SM 9-4-5180-A18
Tool Kit, Small Arms Repairman	SM 9-4-5180-A57

3. Forms

The following forms pertain to this materiel:

DA Form 9-14, Processing Record for Shipment and Storage of File and AA Artillery and Equipment (Tag)
DA Form 468, Unsatisfactory Equipment Report
DA Form 811, Work Request and Job Order (4-part set)
DA Form 2028, Recommended Changes to DA Technical Manual Parts Lists of Supply Manual 7, 8, or 9 (cut sheet)
DD Form 6, Report of Damaged or Improper Shipment

4. Other Publications

The following explanatory publications contain information pertinent to this materiel and associated equipment:

<i>a. Ammunition.</i>	
Safety: Regulations for Firing Ammunition for Training, Target Practice, and Combat	AR 385-63/ AFR 50-13
<i>b. Decontamination.</i>	
Decontamination	TM 3-220
Small Unit Procedures Nuclear, Biological, and Chemical Warfare	FM 21-40
<i>c. General.</i>	
Basic Arctic Manual.....	FM 31-70
Dictionary of United States Army Terms.....	AR 320-5

Issue of Supplies and Equipment: Preparation, Processing, and Documentation for Requisitioning, Shipping, and Receiving.....	AR 725-5
Logistics (General):	
Report of Damaged or Improper Shipment	AR 700-58
Unsatisfactory Equipment Report.....	AR 700-38
Marking and Packaging of Supplies and Equipment: Marking of Supplies for Shipment.....	AR 746-80
Military Symbols	FM 21-30
Military Terms, Abbreviations, and Symbols: Authorized Abbreviations and Brevity Codes.....	AR 320-50
Military Training	FM 21-5
Property Accountability: Accounting for Lost, Damaged, or Destroyed Property.....	AR 735-11
Safety: Accident Reporting and Records	AR 385-40
Targets, Target Materiel, and Training Course Lay-outs	TM 9-855
Techniques of Military Instruction	FM 21-6
 <i>d. Maintenance and Repair.</i>	
Cleaning and Black Finishing of Ferrous Materials	TM 9-1861
Cleaning, Drying, and Abrading Equipment for Cleaning Ordnance Materiel.....	TM 9-208-2
General Packaging Instructions for Ordnance General Supplies.....	TM 9-200
Inspection of Ordnance Materiel in Hands of Troops	TM 9-1100
Maintenance of Supplies and Equipment:	
Command Maintenance Inspections	AR 750-8
Maintenance Responsibilities and Shop Operation	AR 750-5
Materials Used for Cleaning, Preserving, Abrading, Cementing Ordnance Materiel; and Related Materials including Chemicals	TM 9-247
Operation and Maintenance of Ordnance Materiel in Extreme Cold Weather 0 to -65° F.....	TM 9-207
Ordnance Direct Support Service	FM 9-3
Ordnance Service in the Field	FM 9-1
Organizational and Field Maintenance Repair Parts and Special Tools List.....	TM 9-6920-205-45P
Packaging and Shipping of Materiel: Preservation, Packaging, and Packing of Military Supplies and Equipment.....	TM 38-230
Painting Instructions for Field Use	TM 9-2851
Processing of Unboxed Self-Propelled and Towed Class I Ordnance General Supplies and Related Materiel for Shipment and Storage.....	TB 9-299/1
Protection of Ordnance General Supplies in Open Storage	TB ORD 379
Standards for Overseas Shipment and Domestic Issue of Ordnance Materiel other than Ammunition and Army Aircraft.....	TB ORD 385
Supply Procedures: Preservation, Packaging, and Packing of Military Materials, Supplies, and Equipment used by the Army.....	SB 38-230

**APPENDIX II
MAINTENANCE ALLOCATION CHART**

1. Purpose

To allocate specific maintenance operations to the proper echelon.

2. Basis

Allocation of maintenance operations is made on the basis of time, tools, and skills normally available to the various echelons in a combat situation and influenced by maintenance policy and sound maintenance practices as outlined in AR 750-5, FM9-1, and FM 9-3.

3. Explanation and Definitions

The maintenance allocation chart designates overall responsibility for the maintenance functions on an end item or assembly. Repair and/or rebuild of major assemblies is designated by authority of the Army commander representative except for the specific repair subfunction listed in the maintenance allocation chart and authorized only upon approval of the Army commander representative

a. *Service* To clean, to preserve, and to replenish fuel and lubricants.

b. *Inspect* To verify serviceability and to detect incipient electrical or mechanical failure by scrutiny.

. *Replace* To substitute serviceable assemblies, subassemblies, and parts for unserviceable components.

d. *Repair*. To restore to a serviceable condition through correction of a specific failure or unserviceable condition by replacing unserviceable parts or by any other action required; utilizing tools, equipment and skills available, to include welding, grinding, riveting, straightening, adjusting, etc.

e. *Overhaul*. To restore to a completely serviceable condition by a minimum of disassembly, inspection, and repair only as necessary; utilizing tools, equipment, and skills available, followed by assembly and final inspection.

f. *Symbol X* The symbol X placed in the appropriate column indicates the echelon responsible or performing that particular maintenance operation, but does not necessarily indicate that repair parts will be stocked at that level. Echelons higher than the echelon marked by X are authorized to perform the indicated operation.

(1) GROUP NUMBER	(2) COMPONENT & RELATED OPERATIONS	(3) ECHELONS				
		1st	2d	3d	4th	5th
	CABINET ASSEMBLY					
	Service.....	X				
	Repair	X		
	Overhaul	X	
	CHASSIS ASSEMBLY, COUNTER					
	Service	X				
	Inspect.....	X				
	Replace					
	Fuse		X			
	Lamps		X			
	Repair	X		
	Overhaul	X	
	CHASSIS ASSEMBLY, FLASHER					
	Service.....	X				
	Inspect.....	X				
	Replace					
	Fuse	X			
	Lamps	X			

(1) GROUP NUMBER	(2) COMPONENT & RELATED OPERATIONS	(3) ECHELONS				
		1st	2d	3d	4th	5th
	Repair			X		
	Overhaul				X	
	HIT SWITCH ASSEMBLY					
	Service	X				
	Inspect.....	X				
	Repair`			X		
	LIGHT INDICATOR (TARGET)					
	Service	X				
	Inspect.....	X				
	Replace					
	Lamps.....		X			
	TARGET HOLDER ASSEMBLY					
	Service	X				
	Inspect.....	X				
	Repair`			X		
	TERMINAL BOX ASSEMBLY					
	Service	X				
	Inspect.....	X				
	Repair`			X		

APPENDIX III

BASIC ISSUE ITEMS LIST

Section I. PREFACE

1. General

This appendix is a list of the basic issue items that are required for stockage by first echelon maintenance.

2. Explanation of Columns

a. *Source Maintenance, and Recoverability Code.* When supply responsibility of an item has been assigned to a technical service other than Ordnance, the basic number of the supplying technical service is listed in the first position of the source code, in this case 12 for an Adjutant General item. The absence of a code in column 1(d) indicates *the item is expendable and not recoverable.*

b. *Federal Stock Number.* This column lists the Federal stock number which has been assigned by Cataloging Division, Defense Logistics Services Center.

c. *Description.* This column lists the Federal item name (shown in capital letters) and any additional

description required for supply operations. The technical service part number is also included for reference.

d. *Unit of Issue.* The absence of a quantity in this column indicates that a minimum unit of one will be supplied.

e. *Quantity Authorized* This column lists the quantity of the listed item authorized for stockage by first echelon.

f. *Illustration* This column indicates the figure number of the illustration that depicts the item.

3. Suggestions and Recommendations

Notice of discrepancies and recommendations for additions and deletions of repair parts and special tools will be forwarded on DA Form 2028 direct to the Commanding Officer, Arsenal, Metuchen, N. J., ATTN: ORDJR-OCpra.

Section II. BASIC ISSUE ITEMS

(1) Source, maint, and recoverability code				(2)	(3)	(4)	(5)	(6)
(a) Tech Serv. No.	(b) Srce	(c) Main. Lvl	(d) Recv.	Federal Stock Number	Description	Unit Of Time	Quan. Auth.	Illus.
					MAJOR ITEM			
					The following item is requisitioned for initial use only.			
				6920-678-8478	TARGET MECHANISM, NIGHT FIRING: XM 31 (7545932).		1
					MATERIAL ISSUED BY OTHER TECHNICAL SERVICES			
					The following item is issued by The Adjutant General in accordance with distribution formula and AR 310-2. Additional copies, when required, will be requisitioned from The Adjutant Generals Office.			
12					MANUAL technical, TM 9-6920-205-14			
					MISCELLANEOUS MATERIEL			
					The items listed under subheadings below are not issued with the major item, but are requisitioned and issue in accordance with tables of organization and equipment, tables of allowances, or as otherwise authorized.			
					TARGETS			
					Targets for use with this mechanism are listed in TM 9-6920-210-24P.			

INDEX

	<i>Paragraph</i>	<i>Page</i>		<i>Paragraph</i>	<i>Page</i>
Accidents, field report of.....	3c	2	Hot climate operation (See Operation under unusual conditions)		
Army, shipping document (see shipping instructions)			Identification plate	5	5
Authorized form	3b	2	Indicator lights and lamps, description of	4h,11	4,6
Bail handles (See Cabinet assembly)			Inspection during storage (See Storage instructions limited)		
Cabinet assembly:			Maintenance allocation:		
Description	4b	4	Field	2c	2
Repair:			Operator	2a	2
Inspection and repair	41c	19	Organizational	2b	2
Installation of bail handles.....	41d	19	Maintenance, organizational preventive:		
Installation flush catches....	41e	19	By personnel	30	14
Removal of bail handles....	41a	19	General.....	26	13
Removal of flush catches	41b	19	Responsibility of	27	13
Cold climate operation (See Operation under unusual conditions)			Schedule of	29	13
Controls and instruments (See Specifications assemblies, description of.....)	10	6	Services and inspections....	28	13
Counter chassis assembly:			Operation under unusual conditions:		
Description	4c	4	General.....	19	12
Organizational replacement	33b	16	In cold climates.....	20	12
Repair:			In hot climates	21	12
Assembly.....	42d	25	Operation under usual conditions:		
Disassembly	42b	22	Operation	18	10
General	42a	19	Operational check-out	17	10
Inspection.....	42c	22	Preparation for	16	8
Description of night firing target mechanism XM31	4	3	Operational check-out (See Operation under usual conditions)		
Dimensions and weights (See Tabulated data)			Operator maintenance allocation (See Maintenance allocation)		
Electrical system tabulated data (See Tabulated data)			Organizational replacement (see specific items)		
Field maintenance allocation (See Maintenance allocation)			Packing and marking instructions	51	42
Field report of accidents (See Forms, records, and reports)			Parts, special tools, and equipment; general information on	34	18
Flasher chassis assembly:			Personnel, organizational preventive maintenance by (See Maintenance, organizational preventive)		
Description	4d	4	Power toggle switches, description of	12	6
Organizational replacement.....	33a	16	Preparation for operation (See Operation under usual conditions)		
Repair:			Preparation for shipment (See Shipping instructions)		
Assembly	43d	33	Receiving inspections (See Storage instructions , limited)		
Disassembly	43b	29	Receptacle plug connectors, organizational replacement of	3d	17
General	43a	29	Removal from limited storage (See Storage instructions, limited)		
Inspection	43c	29	Repair, general (See specific items)	40,44	19,35
Flush cathesb (See Cabinet assembly)			Repair parts:		
Forms, records, and reports:			Field maintenance.....	35	18
Authorized forms.....	3b	2	Organizational maintenance	23	13
Field report of accidents.....	3c	2	Organizational replacement (See specific items	31	15
General	3a	2	Report of unsatisfactory equipment or materials (See Forms, records, and reports)		
Report of unsatisfactory equipment or materials.....	3	3	Responsibilities, shipping (See Shipping instructions)		
Fuseholders, description of	14	7			
Fuses, organizational replacement Of	32	15			
Hit switch assemblies:					
Description.....	4g	4			
Repair:					
Assembly	47	37			
Disassembly	47b	36			
General	47a	36			
Inspection	47c	37			

	<i>Paragraph</i>	<i>Page</i>
Responsibility of maintenance (See Maintenance, organizational preventive)		
Schedule of maintenance (See Maintenance, organizational preventive)		
Scope, general	1	2
Service and inspections (See Maintenance, organizational preventive)		
Services upon receipt of materiel ..	7, 8	6
Shipping instructions:		
Army shipping documents	49b	41
Preparation for shipment	49c	41
Responsibilities	49a	41
Storage instructions, limited:		
General	50a	41
Inspection during storage	50c	41
Receiving inspections	50b	41
Removal from limited storage .	50d	41
Storage site	50e	42
Storage site (See Storage instructions, limited)		
Tables:		
Preventive-maintenance services by operator (table)		
Preventive-maintenance services by organizational personnel (table)		
Troubleshooting (table IIIH)		
Tabulated data	6	5
Target holder assemblies:		
Description	4f	4

	<i>Paragraph</i>	<i>Page</i>
Repair:		
Assembly	46d	35
Disassembly	46b	35
General	46a	35
Inspection	46c	35
Target, organizational replacement of	33	16
Target selector toggle switches, description of	15	8
Terminal box assembly:		
Description	4e	4
Repair :		
Assembly	45d	35
Disassembly	45b	35
General	45a	35
Inspection	45c	35
Tools and equipment:		
Common:		
Field	36	18
Organizational	24	13
Special:		
Field	37	18
Organizational	25	13
Troubleshooting, scope of	39	18
Unsatisfactory equipment or materials, report of	6d	5
Utility box assemblies:		
Description	4i	5
Repair	48	38
Variable resistors description of	13	6

By Order of Secretary of the Army:

G. H. DECKER,
General, United States Army,
Chief of Staff.

Official:

J. C. LAMBERT,
Major General, United States Army,
The Adjutant General

Distribution:

Active Army:

DCSLOG (1)	Raritan Arsenal (10)
CNGB (1)	Rock land (5)
Tech Stf, DA (1) except	Ft Dix (2)
CofOrd (9)	Camp Drum (2)
CofT (None)	Ft Devens (2)
Ord Bd (2)	Ft George G. Meade (2)
USCONARC (3)	Ft Knox (2)
ARADCOM (2)	Camp A. P. Hill (2)
ARADCOM Rgn (2)	Ft Benning (2)
OS Mai Comd (2) except	Ft Jackson (2)
USAREUR (3)	Ft Campbell (2)
USARJ (3)	Ft McClan (2)
OS Base Comd (2)	Ft Hood (2)
LOGCOMD (3)	Ft Sill (2)
MDW (2)	Ft Bliss (2)
Armies (3)	Ft Leonard Wood (2)
Corps (2)	Ft Riley (2)
USA Corps (1)	Ft Carson (2)
Svc Colleges (1)	Camp McCoy (2)
USMA (1)	Ft Lewis (2)
OWC (64)	Ft Ord (2)
GENDEP (2)	Units org under fol TOE:
Ord See, GENDEP (1)	(2 copies each)
Ord Dep (2)	7
OSA (1)	17
Ord arsenal (2) except	57

NG 5 USAR: None.

For explanation of abbreviations used, see AR 320-50.

* U.S. GOVERNMENT PRINTING OFFICE : 1988 0 - 219-546

RECOMMENDED CHANGES TO EQUIPMENT TECHNICAL PUBLICATIONS



SOMETHING WRONG WITH THIS PUBLICATION?

FROM: (PRINT YOUR UNIT'S COMPLETE ADDRESS)

DATE SENT

PUBLICATION NUMBER

PUBLICATION DATE

PUBLICATION TITLE

BE EXACT... PIN-POINT WHERE IT IS

PAGE NO.

PARA-GRAPH

FIGURE NO.

TABLE NO.

IN THIS SPACE TELL WHAT IS WRONG AND WHAT SHOULD BE DONE ABOUT IT:

TEAR ALONG PERFORATED LINE

PRINTED NAME, GRADE OR TITLE, AND TELEPHONE NUMBER

SIGN HERE:

DA FORM 2028-2
1 JUL 79

PREVIOUS EDITIONS
• ARE OBSOLETE.

P.S.—IF YOUR OUTFIT WANTS TO KNOW ABOUT YOUR RECOMMENDATION MAKE A CARBON COPY OF THIS AND GIVE IT TO YOUR HEADQUARTERS.

PIN NO: 028048-000